

ADT-CNC4640

CNC46XX Series CNC System

Maintenance Manual

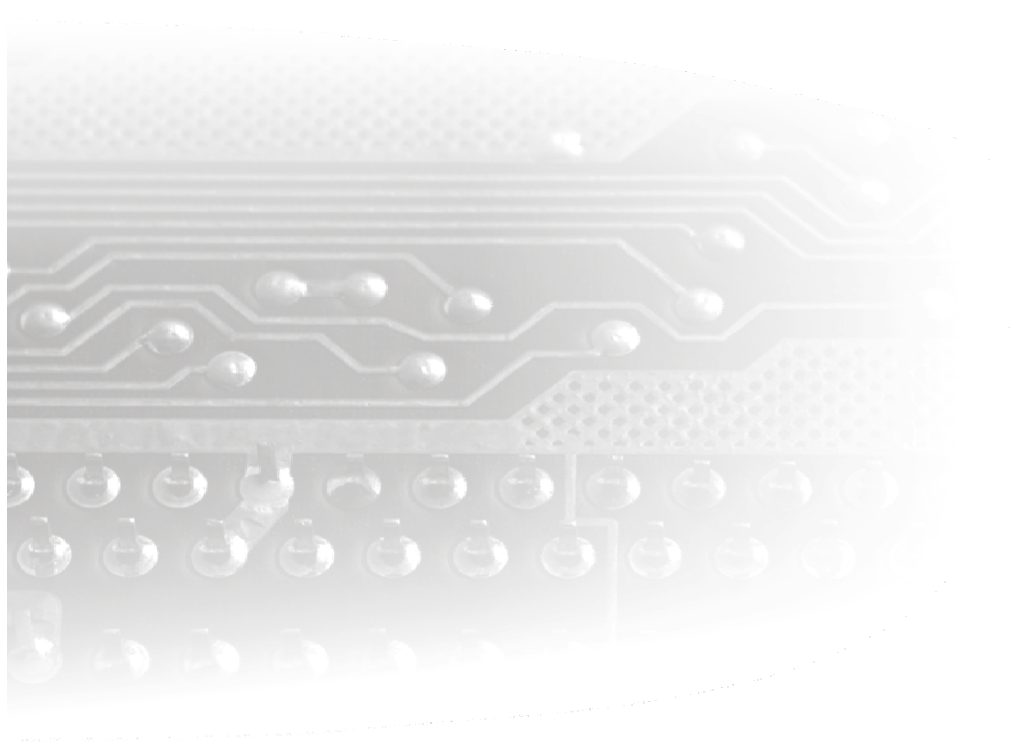

ADTECH 众为兴

Adtech (Shenzhen) CNC Technology Co., Ltd.

Add: 5/F, Bldg/27-29, Tianxia IC Industrial Park, Yiyuan Rd, Nanshan District, Shenzhen

Postal code: 518052

Tel: 0755-26722719

Fax: 0755-26722718

E-mail: export@machine-controller <http://www.machine-controller.com>

Copyright

Adtech (Shenzhen) Technology Co., Ltd. (Adtech hereafter) is in possession of the copyright of this manual. Without the permission of Adtech, the imitation, copy, transcription and translation by any organization or individual are prohibited. This manual doesn't contain any assurance, stance or implication in any form. Adtech and the employees are not responsible for any direct or indirect data disclosure, profits loss or cause termination caused by this manual or any information about mentioned products in this manual. In addition, the products and data in this manual are subject to changes without prior notice.

All rights reserved.

Adtech (Shenzhen) Technology Co., Ltd.

Contents

1. Foreword	- 3 -
2. System technical characteristics	- 3 -
2.1 System structure	- 3 -
2.2 System technical parameters	- 3 -
2.3 System function.....	- 5 -
2.3.1 Self-diagnosis.....	- 5 -
2.3.2 Compensation	- 5 -
2.3.3 Abundant instruction system.....	- 5 -
2.3.4 Full Chinese menu operation & full screen edit	- 5 -
2.3.5 Abundant error-correction functions	- 5 -
2.3.6 Program exchange between CNC system and PC.....	- 5 -
2.4 System operating condition.....	- 5 -
3. Operating panel	- 6 -
3.1 LCD/keypad	- 6 -
3.2 LCD brightness adjustment	- 7 -
3.3 System menus.....	- 8 -
3.4 Operating keys.....	- 11 -
4. Manual operation	- 12 -
4.1 Returning to reference point manually	- 12 -
4.2 Continuous feeding manually.....	- 13 -
4.3 Single step feeding	- 13 -
4.4 Handwheel feeding.....	- 13 -
4.5 Manual auxiliary function operation	- 14 -
4.6 Tool setting	- 15 -
4.6.1 Centered (M series).....	- 15 -
4.6.2 Tool regulator (M series).....	- 16 -
4.6.3 Tool setting by test cutting (L series)	- 17 -
4.7 Data settings	- 17 -
4.7.1 Tool compensation data setting	- 17 -
4.7.2 System parameter setting	- 17 -
5. Automatic operation	- 18 -
5.1 Memory operation	- 18 -
5.2 MDI operation	- 18 -
5.3 USB disk DNC	- 18 -
5.4 Speed rate adjustment.....	- 18 -
5.5 Run idle	- 19 -
5.6 SBK function.....	- 19 -
5.7 BDT function.....	- 19 -
5.8 Stopping automatic operating.....	- 19 -
6. Safe operation	- 20 -
6.1 Emergency stop.....	- 20 -
6.2 Hard limit over travel	- 20 -
6.3 Soft limit over travel	- 20 -
7. Alarm and self- diagnosis function	- 21 -
7.1 NC program execution alarm	- 21 -
7.2 System environment alarm.....	- 22 -
7.3 Alarm processing.....	- 23 -
7.4 Self-diagnosis function.....	- 24 -
8. Program saving & editing	- 25 -
8.1 Saving the program in the memory	- 25 -
8.1.1 Keypad input (new program)	- 25 -
8.1.2 PC serial port input	- 25 -
8.1.3 Copying processing files from USB disk	- 25 -
8.2 Reading programs into work area	- 25 -
8.2.1 Reading programs from controller into work area	- 25 -
8.2.2 Reading programs from USB disk into work area	- 25 -
8.3 Editing & modifying programs	- 25 -
8.4 Deleting files	- 26 -
8.4.1 Deleting files in memory.....	- 26 -
9. Main interfaces of the system	- 27 -

9.1 Position interface	- 27 -
9.2 Edit interface.....	- 29 -
9.3 MDI interface	- 30 -
9.4 File management.....	- 31 -
9.5 Graphic simulation.....	- 31 -
9.6 Parameter interface.....	- 32 -
9.7 Compensation interface	- 35 -
9.8 M series workpiece coordinate system setting interface.....	- 36 -
9.9 Controller diagnosis interface (diagnosis)	- 39 -
9.10 Macro variable view interface (macro variable).....	- 39 -
9.11 Current mode instruction info.....	- 40 -
10. System maintenance.....	- 41 -
10.1 Restart.....	- 41 -
10.2 System upgrade.....	- 41 -
10.3 Reset	- 41 -
10.4 Parameter backup and restore.....	- 41 -
10.5 Entering BIOS	- 41 -
11. System parameters.....	- 42 -
11.1 Parameter index list	- 42 -
11.2 Comprehensive parameters (P1.).....	- 52 -
11.3 Axis parameter configuration (P2.).....	- 62 -
11.4 Management parameters (P3.)	- 69 -
11.5 Tool magazine parameters (P4.).....	- 72 -
11.6 Principal axis parameters (P5.)	- 73 -
11.7 Port configuration (P6.)	- 74 -
12. Hardware interface definition and connection instructions	- 76 -
12.1 Installation layout	- 76 -
12.1.1 External interface diagram	- 76 -
12.1.2 Mounting dimensions.....	- 77 -
12.1.3 Installation precautions	- 78 -
12.2 Interface definition.....	- 80 -
12.2.1 Motor drive control interface (XS1..XS4).....	- 80 -
12.2.2 Digital input interface (XS5).....	- 83 -
12.2.3 Digital output interface (XS6).....	- 86 -
12.2.4 Handheld box interface (XS7).....	- 89 -
12.2.5 Analog output interface (XS8)	- 90 -
12.2.6 Principal axis encoder interface (XS12).....	- 91 -
12.2.7 RS232 transmission interface (XS9)	- 93 -
12.2.8 USB memory connection interface (XS10).....	- 93 -
12.2.9 PC USB communication interface (XS11)	- 93 -
12.3 Electrical connection diagram	- 94 -
12.3.1 Symbol schematic diagram	- 94 -
12.3.2 Power connection diagram.....	- 95 -
12.3.3 Servo drive connection diagram.....	- 96 -
12.3.4 Step connection diagram	- 97 -
12.3.5 IO electrical connection diagram.....	- 98 -

1. Foreword

CNC4640/4620 numerical control system is economic embedded system developed by Adtech (Shenzhen) CNC Technology Co., Ltd. for milling machines and machining centers, where CNC4640 is four axes motion controller and CNC4620 is two axes motion controller.

Instructions and reading convention of the Manual

Before using this CNC system, please read this Manual carefully to operate properly.

Terminology note and reading convention in this Manual:

CNC4640 and CNC4620 are control systems with different axes and same hardware functions. The programs developed on this platform contain M series software for milling machines and L series software for lathes. Different software has different functions and masks.

M series are system for milling machine motion. The ‘M’ or “M series” mark indicates specific interface or function for milling machine software system.

L series are system for lathe motion. The ‘L’ or “L series” mark indicates specific interface or function for lathe software system.

“CNC system”, “NC controller” and “CNC46XX” mentioned in this Manual all refer to CNC4640/4620;

The articles marked with “Caution” prompt users to pay special attention for operation or setting, or else this operation may fail or certain action can’t be performed.

2. System technical characteristics

2.1 System structure

- CPU: ARM industrial mainboard;
- Communication: USB interface;
- Capacity: 64MB RAM, 60M Flash ROM;
- Feedback: AB phase pulse feedback;
- Control: FPGA motion controller;
- Hand pulse: Incremental hand encoder;
- Display: 800×480 pixels 7” LCD;
- I/O full optical coupling isolation;
- Touch/film type operation panel;
- Highly anti-interference switching power supply;
- RS232 interface

2.2 System technical parameters

Function	Name	Specification
Control axis	Control axes	4 axes (CNC4640 series) 2 axes (CNC4620 series)
	Simultaneous control axes	4 axes linear interpolation (CNC4640 series) 2 axes linear interpolation (CNC4620 series) 2 axes arc interpolation
Input instruction	Minimum setting unit	0.001mm
	Minimum moving unit	0.001mm
	Maximum instruction value	±9999.999mm

Function	Name	Specification	
Feeding	Fast feeding speed	X axis, Y axis, Z axis, A axis: 9999 mm/min (maximum)	
	Feeding speed range	Per minute	1~9999mm/min
		Per rotation	1~500rpm
	Automatic acceleration/deceleration	Yes	
	Feeding speed rate	10~150%	
Manual	Continuously manual feeding,	Yes	
	Returning to reference point manually	All control axes return to reference point simultaneously (allow setting order of priority)	
	Single step/handwheel function	Yes	
Interpolation	Positioning, linear interpolation, arc interpolation	G00, G01, G02/G03	
Operating mode	MDI, auto, manual, single step, edit	Yes	
Testing function	Test run, single program section, Handwheel	Yes	
Coordinate system and pause	Pause (sec/ms)	G04 X/P_	
	Coordinate system setting	G92 (M series) G50 (L series)	
	Automatic coordinate system setting	Yes	
Safe functions	Soft & hard limit check	Yes	
	Emergency stop	Yes	
Program storage	Program storage capacity, storage quantity	Capacity: 60MB 100 work areas No limit on processing file quantity	
Program edit	Program edit	Insert, modify, delete, cancel	
	Program No., sequence No., address, character retrieval	Yes	
	Decimal point programming	Yes	
Display	800×480 pixels 7" LCD		
	Position screen, program edit Tool compensation setting, alarm display Handwheel test, diagnosis screen Parameter setting, graphic simulation	Yes	
M, S, T function	Auxiliary function	M code	
	Principal axis function	S0-S15 (gear position control) S15-S99999 (analog)	
	Tool function	T code	
Compensation function	Tool compensation memory	30 tools length, radius compensation	
	Reverse clearance compensation	Yes	
Other functions	Measurement centered Automatic tool regulator	Yes	
	Specify arc radius R/center position	Yes	
	Electronic gear ratio	Yes	

2.3 System function

2.3.1 Self-diagnosis

Diagnose CPU, memory, LCD, I/O interface, parameter state, coordinates and processing program comprehensively every time the system is started or reset; diagnose power supply, principal axis, limit and I/O ports in real-time during operating.

2.3.2 Compensation

- Automatic reverse clearance compensation
- Automatic tool length compensation
- Automatic tool radius compensation
- Automatic tool radius biasing and automatic tool tip transition

2.3.3 Abundant instruction system

- Scaling instruction
- Mirror processing instruction
- Tool biasing instructions
- Program cycle, program skip, program shift, program transfer, different end processing modes, macro definition and program management instructions
- Fixed-point instructions: starting point, setting point, etc.
- Linear, arc and spiral interpolation instructions
- Six workpiece coordinate systems, nine extension coordinate systems and one reference point

2.3.4 Full Chinese menu operation & full screen edit

4640/4620 CNC system uses cascading menu structure and full Chinese operation to ensure simple operation and visibility.

2.3.5 Abundant error-correction functions

Point out the nature and correct the errors in operation.

2.3.6 Program exchange between CNC system and PC

Perform CAD/CAM/CAPP auxiliary programming with abundant software in PC, and then transmit CNC program to the system through communication interface (USB disk, RS232 interface), or transmit the programs from the system to PC.

2.4 System operating condition

Operating voltage	24V DC (with filter)
Operating temperature	0°C—45°C
Optimum operating temperature	5°C—40°C
Operating humidity	10%—90% (no condensing)
Optimum operating humidity	20%—85%
Storage temperature	0°C—50°C
Storage humidity	10%—90%
Operating environment	No excessive dust, acid, alkali, corrosive and explosive gases, no strong electromagnetic interference

3. Operating panel

3.1 LCD/keypad

Keypad

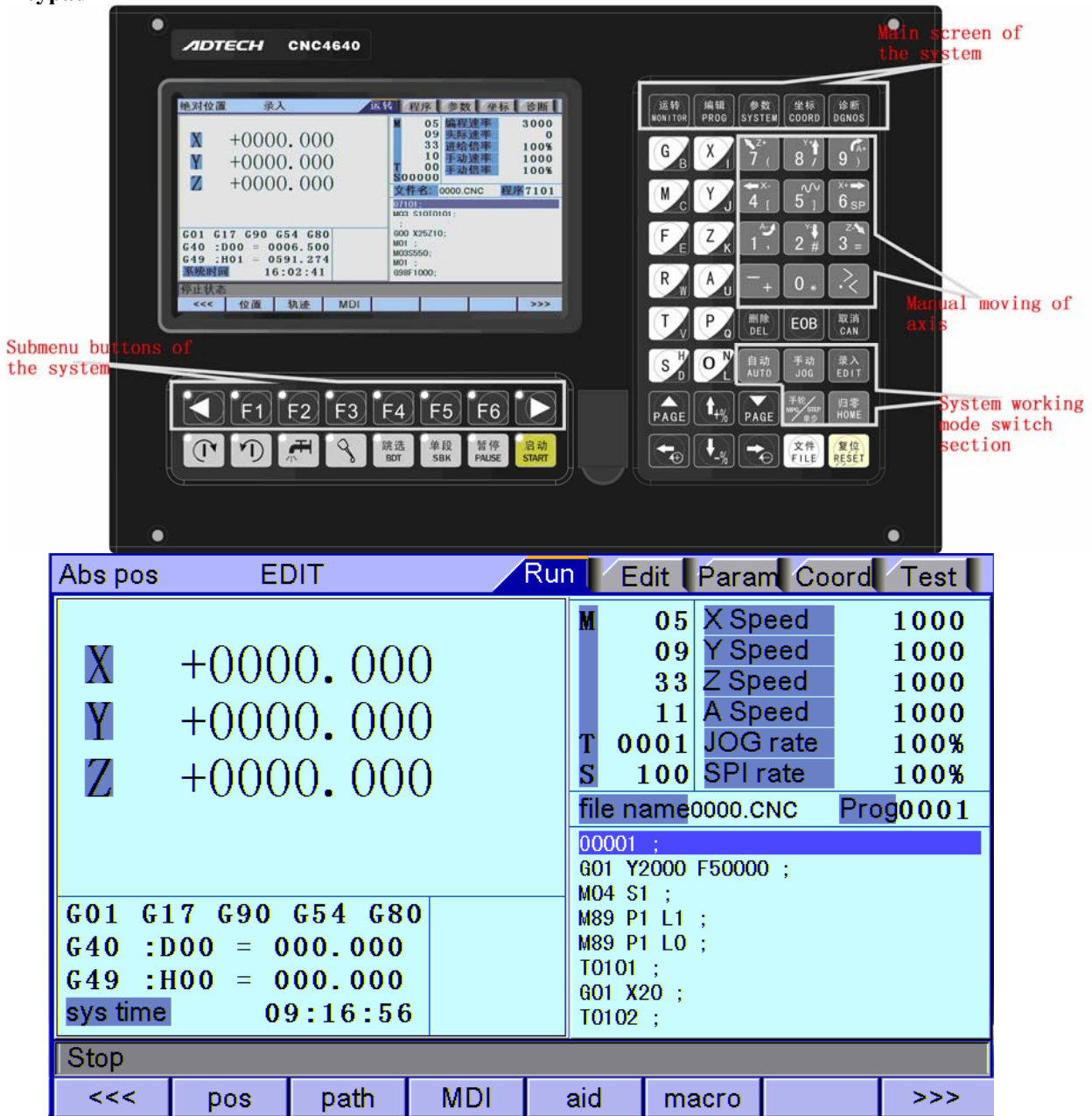

Fig. 3.1 CNC4640 Operating Panel Diagram

Note:

Press the submenu buttons to perform the operations of submenus.

Manual axis moving and edit & input are composite. It has different definitions according to the modes.

System working mode switch section is used to switch working modes, which can improve the security and system performance. Handwheel and single step mode are switched with Repeat button.

LCD unit

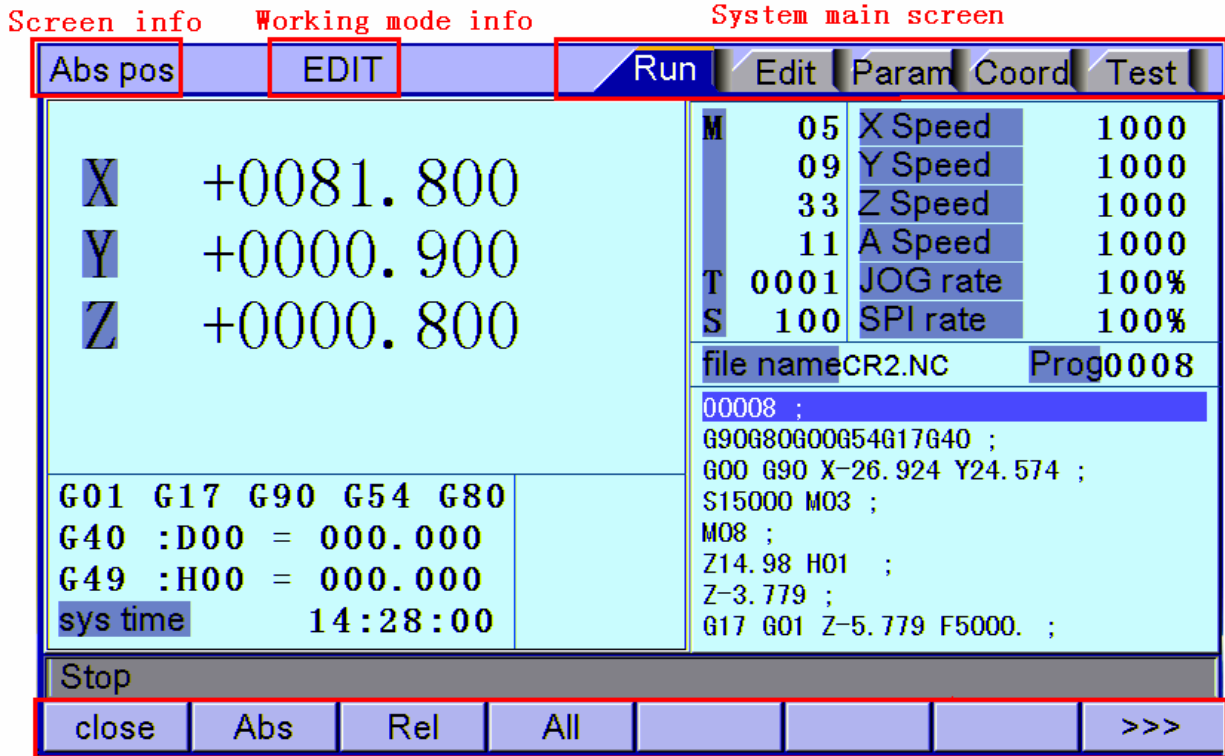

Submenu options

Fig. 3.2 CNC4640 LCD Screen Diagram

Note:

Screen info shows the information of current window

Working mode info shows currently selected working mode

System main screen shows current main screen.

The submenu options are used to switch submenus with left triangle, F1~F6 and right triangle. The right arrow is used to turn pages, and the left arrow is used to close the submenus in next level and previous menu.

3.2 LCD brightness adjustment

CNC46XX doesn't support brightness adjustment.

3.3 System menus

CNC46XX system uses cascading menu structure. You can press the following keys to operate the menus.



Press a key to show the corresponding content in the bottom of the LCD.

Key in the left: Return to previous menu

Key in the right: Turn pages to show other menus of same level

The main menus of the system include [Monitor], [Edit], [Parameter], [Coordinate] and [Diagnosis]. Each main menu contains several submenus, which are shown below:

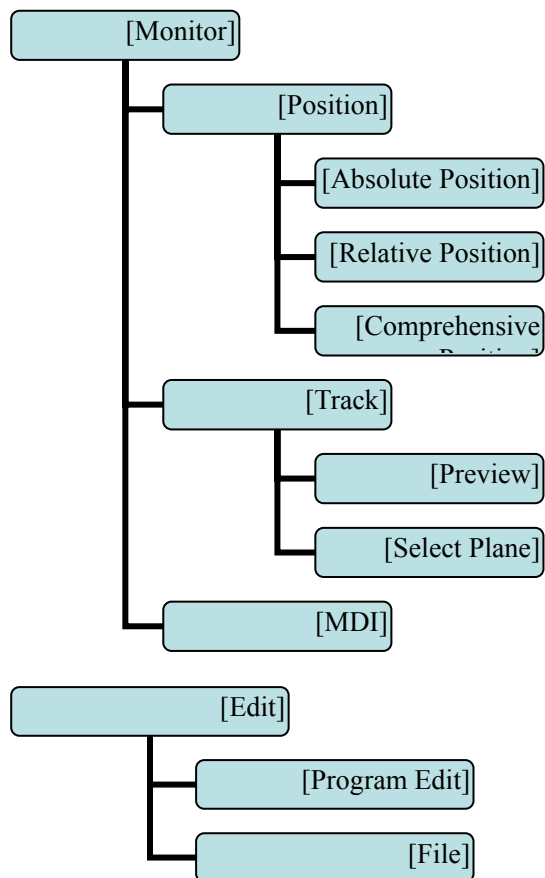

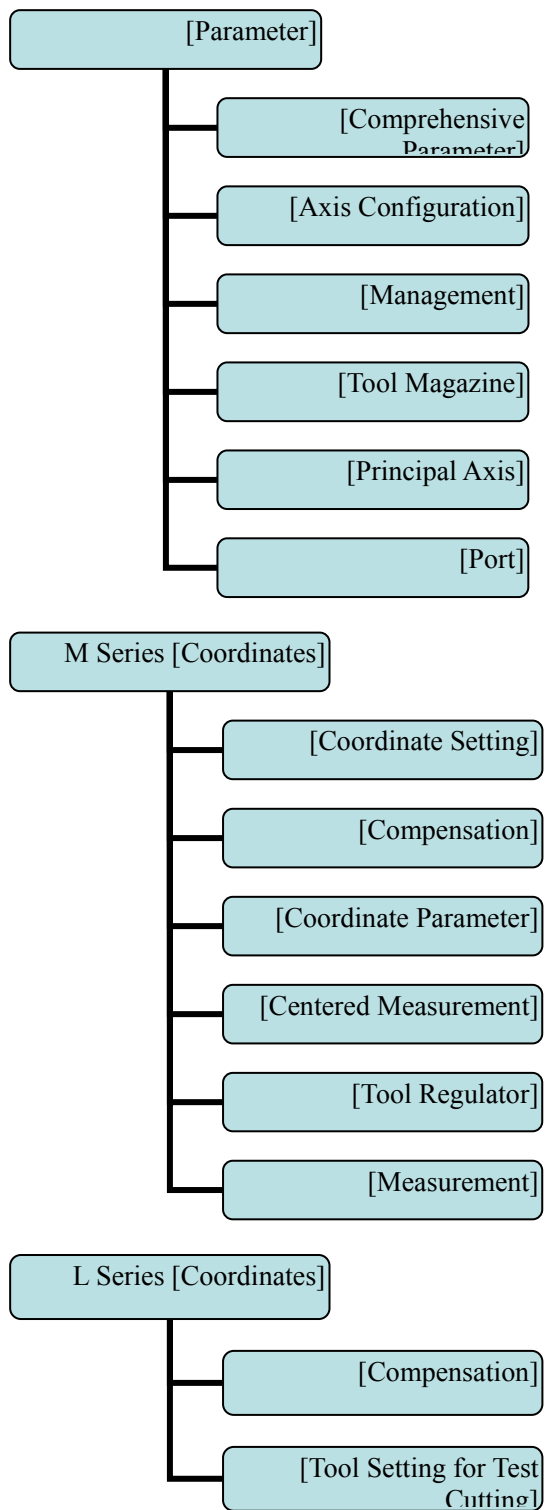

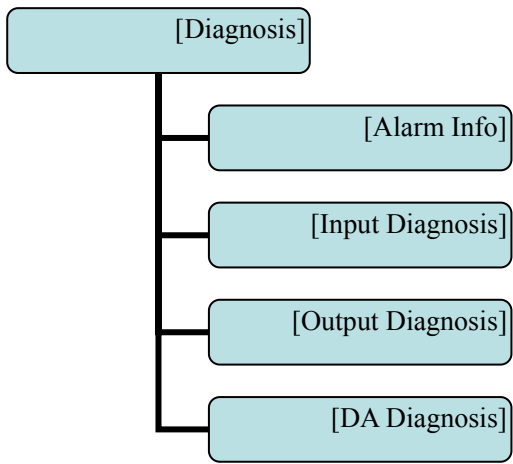

3.4 Operating keys

The keys of CNC46XX system are defined below:

Key	Purpose
[RESET]	Cancel alarm, reset CNC
Address/number keys	Enter letters, numbers, etc.
[EOB], [CAN]	Confirm or cancel operation
[EOB], [CAN], [DEL]	Program edit (insert, delete, modify)
Mode switch key	Select operating mode
Cursor moving key	Four keys are available: Up/Down: adjust ration, move cursor between subsections; Left/Right: move cursor to left/right
Page key	Up/Down: Turn pages
Menu keys	Select the menus
Principal axis positive rotation	Press it to rotate the principal axis positively, and press it again to stop rotating
Principal axis reverse rotation	Press it to rotate the principal axis reversely, and press it again to stop rotating
Coolant	Coolant on/off
Lubricant	Lubricant on/off
[BDT]	Block delete on/off
[SBK]	Single block function on/off
[PAUSE]	Pause automatic running
[START]	Start automatic running

4. Manual operation

4.1 Returning to reference point manually

CNC machine tool has specific mechanical position, which is called as reference point and for tool exchange and coordinates setting. Generally, when the power supply is connected, the tool should be moved to the reference point. This operation is also called as home operation, which will make the CNC system confirm the origin of machine tool.

The home operation includes program and mechanical mode:

For program home, the action completes when the coordinates of machine tool are 0, and won't check whether origin switch is in position;

For mechanical home, the external home sensor switch is used to locate the origin of the machine tool; two checking modes are available:

With the external sensor switch, the home operation completes when the sensing is successfully repeatedly.

The external sensor switch is used as deceleration switch, the servo home is enabled as home signal after sensing and then the sensing stops.

You can set the "Home mode" in [Parameter][Comprehensive Parameter], in which 0 (default) indicates program and 1 indicates mechanical. You can also press [SBK] key in home mode to switch among "Mechanical – Program – Mechanical..." quickly. This method doesn't conflict with parameter setting. You can select accordingly. To use servo home as the home signal, you need to set "Axis phase Z home enable" to "1" in [Parameter][Axis Configuration] in mechanical home mode, and the setting will take effect in next home checking.

Several methods are available for tool returning to reference point and the steps follow:

(1) Each axis returns to reference point separately

- Press the mode switch key [Home] to select home operation;
- Press the composite key [X-], [Y-], [Z-], [A-] in the numbers section to return the corresponding axis to reference point.

(2) The axes return to reference point simultaneously

- Press the mode switch key [Home] to select home operation;
- Press the [Start] key to return Z axis to reference point, and other axes return to reference point simultaneously. The automatic home sequence can be configured in the parameters.

(3) Reset machine tool position

- Press the mode switch key [Home] to select home operation;
- In [Absolute Position] and [Coordinate System] screen, press [X], [Y], [Z], [A] respectively to show the value of corresponding axis position, and then press the [Cancel] key to reset the machine tool position of current axis, i.e. current point is used as machine tool origin. After this operation, the system considers it as a home action. Therefore, when the program is running, the alarm of not home won't occur. If you press by mistake, it will switch the screen and cancel selection automatically.

(4) Reset relative position manually

- Press the mode switch key [Manual] to select manual operation;
- In [Relative Position] and [Coordinate System] screen, press [X], [Y], [Z], [A] respectively to show the value of corresponding axis, and then press the [Cancel] key to reset the relative position of current axis.



Note

The tool also can return to reference point according to program instruction, i.e. returning to reference point automatically.



Caution:

Generally, the system will perform home operation after connecting the power supply. If the power fails while the machine tool is moving, the system also will return to reference point when the power supply is connected again. Return to Z axis to prevent tool and workpiece from colliding, and damaging tool, workpiece and clamp.

4.2 Continuous feeding manually

Press the keys on the operation panel or handwheel to move the tool along every axis.

The operation follows:

- (1) Press the mode switch key [Manual] to select manual operation;
- (2) Press composite keys [X+], [X-]; [Y+], [Y-]; [Z+], [Z-]; [A+], [A-] in numbers area to move the tool along selected axis. The keypad follows:



In manual mode, 5# key can be used to switch the manual speed and rapid traverse speed. The rapid traverse speed of every axis depends on comprehensive parameter 009-012 (rapid traverse speed setting). After switching to rapid traverse speed, the manual speed of the position interface will be highlighted, while the actual speed of the position interface is sampled from the moving speed of current axis. This value can truly reflect the moving speed of current axis (unit: mm/min);

Note

Only single axis motion is available in manual mode.

4.3 Single step feeding

Single step mode is similar to manual mode, the operations are same, but only moves a specified pulse increment every time press the key.

The specific operation follows:

- (1) Press the mode switch key [Handwheel/Single step] (this key is composite, and you can press it repeatedly to switch the modes) to select the single step operation;
- (2) Press composite keys [X+], [X-]; [Y+], [Y-]; [Z+], [Z-]; [A+], [A-] in numbers area to move the tool for a fixed distance along the selected axis. This distance is controlled by four rates (1.000, 0.100, 0.010, 0.001) (unit: mm). To select pulse increment, press Up (+) and Down (-) key in the [Position] interface.

4.4 Handwheel feeding

In handwheel mode, rotate the handwheel to make the machine perform single step or continuous motion. Determine the feed by testing the handwheel signal of the handheld box. In handwheel mode, the feeding axis and feeding unit are determined by the axis selection signal of the handheld box.

The handwheel feeding step follows:

- (1) Press the mode switch key [Handwheel/Single step] to select handwheel operation;
- (2) Rotate the dip switch on the handwheel to select handwheel axis (X, Y, Z, A);
- (3) Rotate the increment dip switch on the handwheel to select the moving amount (0.1, 0.01, 0.001);
- (4) Rotate the handwheel to move the machine tool. The tool moves certain distance every time you rotate the handwheel for a scale. (For example, if you select X axis in step (2) and select 0.01 in step (3), the tool moves 0.01mm every scale). Rotate the handle continuously to move the machine tool on this axis continuously.

Note

The handwheel feeding mode controls only one coordinate axis every time; the faster the handwheel rotates, the faster the machine tool moves.

4.5 Manual auxiliary function operation

Coolant on/off



In handwheel/single step/manual mode, press this key to switch on/off the coolant.

Key indicator: No matter in what mode, the key indicator is on if only the coolant is on, or else the indicator is off.

Lubricant on/off



In handwheel/single step/manual mode, press this key to switch on/off the lubricant.

Key indicator: No matter in what mode, the key indicator is on if only the lubricant is on, or else the indicator is off.

Principal axis positive rotation/stop



In handwheel/single step/manual mode, press this key to rotate the principal axis positively and press it again to stop the axis.

Key indicator: No matter in what mode, the key indicator is on if only the principal axis is positive rotating, or else the indicator is off.

Principal axis reverse rotation/stop



In handwheel/single step/manual mode, press this key to rotate the principal axis reversely and press it again to stop the axis.

Key indicator: No matter in what mode, the key indicator is on if only the principal axis is reverse rotating, or else the indicator is off.

General instructions for manual operation keys

Cooling, lubricant, principal axis positive/reverse rotation are available in handwheel, single step and manual mode;

When the principal axis is rotating, press the reverse rotation key, the principal axis will stop first, and rotate in reverse direction after pressing it again.

When auxiliary output is on, if the system is switched to other modes, the output is unchanged; you need to press "Reset" key to switch it off, execute the corresponding M code in automatic mode or execute the corresponding M code in MDI interface to turn off the output;

When the principal axis is positive/reverse rotating and execute M04/M03 directly, the system first stops positive/reverse rotating and then execute M04/M03 instruction;

Positive/reverse rotating of principal is stopped while emergency stop, and other outputs can be set according to system parameters.

4.6 Tool setting

Tool setting is the main operation and important skill during CNC processing. Under certain conditions, tool setting precision can determine the processing precision of parts, and the tool setting efficiency also affects the CNC processing efficiency directly. CNC46XX has M series tool setting mode and L series tool setting mode, while M series has two tool setting methods, i.e. centered and tool regulator, and L series uses test cutting.

4.6.1 Centered (M series)

The centered function is that the system calculates the center position of the workpiece automatically while tool setting to realize segment centered, rectangle centered and circle center location.

 **Note**

In the tool setting operation below, if the auxiliary parameters of the coordinate system doesn't need setting, the first three steps can be omitted. Please refer to chapter 9.5 for auxiliary parameters of the coordinate system.

(1) Single axis centered

- Select the edit mode;
- Press [Coordinates], [Coordinates Parameter] to enter the auxiliary parameters setting interface of the coordinate system;
- Move the cursor to desired position, enter new parameters and press [EOB];
- Select handwheel or manual mode;
- Press [Coordinates] to enter coordinate system setting interface;
- Press the left/right arrow to move the cursor to select coordinate system;
- Press [Centered Measurement] to enter centered interface;
- Move the tool to make its side blade touch side A surface of the workpiece, and press [EOB] to record boundary point 1;
- Move the tool to make its side blade touch side B surface of the workpiece, and press [EOB] to record boundary point 2;
- Press [EOB] to calculate the coordinates of center point;
- If there is no question, press [EOB] again to return the result to specified coordinate system.

(2) Square centered

- Select the edit mode;
- Press [Coordinates], [Coordinates Parameter] to enter the auxiliary parameters setting interface of the coordinate system;
- Move the cursor to desired position, enter new parameters and press [EOB];
- Select handwheel or manual mode;
- Press [Coordinates] to enter coordinate system setting interface;
- Press the left/right arrow to move the cursor to select coordinate system;
- Press [Centered Measurement] to enter centered interface;
- Move the tool to make its side blade touch side A surface of the workpiece, and press [EOB] to record boundary point 1;
- Move the tool to make its side blade touch side B surface of the workpiece, and press [EOB] to record boundary point 2;
- Record boundary point 3.4 in the same method;
- Press [EOB] after recording all boundary points to calculate the coordinates of center point;
- If there is no question, press [EOB] again to return the result to specified coordinate system.

(3) Plane circle (XY plane) centered

Circle centered has two modes, which are three points and two points with specified radius; If the user only types two coordinates in the option of workpiece boundary point and specifies one value for R, the system will determine the circle center with two points and radius automatically; if the user types coordinates of three points in the option of workpiece boundary point, the system will determine the circle center with three points and shield R.

The centered step of three points arc follows:

- Select the edit mode;
- Press [Coordinates], [Coordinates Parameter] to enter the auxiliary parameters setting interface of the coordinate system;
- Move the cursor to desired position, enter new parameters and press [EOB];
- Select handwheel or manual mode;
- Press [Coordinates] to enter coordinate system setting interface;
- Press the left/right arrow to move the cursor to select coordinate system;
- Press [Centered Measurement] to enter centered interface;
- Move the tool to make its side blade touch the surface of round workpiece, and press [EOB] to record boundary point 1;
- Move the tool to make its side blade touch another point in the surface of the workpiece, and press [EOB] to record boundary point 2;
- Move the tool to make its side blade touch another point in the surface of the workpiece, and press [EOB] to record boundary point 3;
- Press [EOB] after recording all boundary points to calculate the coordinates of circle center and display in the result section;
- If there is no question, press [EOB] again to return the result to specified coordinate system.

Arc centered validation

In the main menu, press [Monitor], [MDI] to enter the MDI interface, select edit mode, enter program block G55G0X0Y0 (if coordinate system G55 is selected while tool setting), press [Start], [EOB], and the tool moves to workpiece center automatically, indicating that three points arc centered properly.

The validation steps for other tool setting methods are same.

4.6.2 Tool regulator (M series)

Tool regulator principle:

The tool regulator uses external sensor switch to set the reference point for axis Z, which is similar to home. After changing tool during processing or changing tool manually, transfer this function to automatically check the Z value of current workpiece's home.

Tool regulator usage

Before using the tool regulator, you need to set the parameters. In [Coordinate] menu, press [Coordinate Parameter] to show tool setting parameters. After that, press [Tool Regulator] in the setting interface to execute the tool regulator program according to specified parameters.

The action sequence of tool regulator follows

- Return Z axis to mechanical home first, and then locate principal axis to X, Y coordinates of the tool regulator;
- Tool regulator blows to start;
- Z axis moves down, and retracts when touches tool regulator sensor switch, moves down at lower speed when the sensor switch leaves, records the machine tool coordinates of current Z axis when touches the switch and assigns to the Z coordinates of current selected coordinate system;
- Tool regulator blows to turn off;
- Z axis returns to home position.

4.6.3 Tool setting by test cutting (L series)

The machine tool uses test cutting for tool setting, which moves the tool to cut the processing file, measures the value after cutting and enters into the system to complete the tool setting for center point.

For tool setting by test cutting, enter the test cutting interface first.

- Press [Coordinate], [Tool Setting] to enter tool setting interface;
- Move cursor to desired tool number, and select diameter or length for the type of current test cutting;
- Select handwheel, single step or manual mode;
- Press the principal axis on, and then press [X+] [X-] [Z+] [Z-] to move the axis and test cutting the workpiece;
- After test cutting, turn off the principal axis but do not move the axis;
- Select edit mode, measure corresponding data and display data, press the number keys to enter directly, press [EOB] to calculate and save automatically, or press [Cancel] to exit;



Caution

1. For tool setting by test cutting, automatically calculate the entered measurement value plus current machine tool coordinates and then enter. Therefore, the current position of machine tool must be true.
2. When measuring the diameter of workpiece, test cutting a layer of the workpiece surface. After cutting, the axis can only retract in opposite direction. Do not move X axis, or else the measured diameter will be invalid.
3. Measure the length of the workpiece, touch the workpiece end with the tool, make it can be cut; enter length value 0, indicating that current point is the workpiece home of Z axis.

4.7 Data settings

4.7.1 Tool compensation data setting

The tool compensation parameters can be set as follow:

- Select the edit mode;
- In the main menu, press [Coordinate], and then press submenu [Compensation] to enter tool compensation parameter setting interface;
- Move cursor to select the parameter, enter the value and then press [EOB] to modify the parameter where the cursor locates.

4.7.2 System parameter setting

The system parameters can be modified as follow:

- Select the edit mode;
- In the main menu, press [Parameter] to enter parameter setting interface;
- Then, press the submenu key to select the parameter type (comprehensive, management ...);
- Move cursor to select the parameter, enter the value and then press [EOB] to modify the parameter where the cursor locates.

5. Automatic operation

The machine tool moving according to prepared program is called as automatic operation. The automatic operation modes of CNC46XX system follow:

Memory operation, MDI operation, USB disk DNC operation.

5.1 Memory operation

The machine tool can operate according to the program in CNC46XX memory, which is called as memory operation.

The program is prestored in the memory. Select and load a program with the operation panel and press the “Start” key to start the automatic operation. Then, press “Pause” key to pause, press “Start” key again to resume the operation, and press “Reset” during operation to stop the program immediately.

The step of memory operation follows:

- (1) Save the program in the memory (see 8.1 for details);
- (2) Select [Edit], [File] in the menu or press [File] on the panel to enter file operation interface;
- (3) Press the direction keys to move the cursor, press [EOB] to select a program and load the file into the work area;
- (4) Press mode selection key [Auto] to switch to automatic mode;
- (5) Press the [Start] key to run the program, and the indicator is on.

5.2 MDI operation

In [Monitor] interface, switch to [MDI], enter the program with keypad and make the machine tool operate according to the program. The program block isn't saved in system memory, and can't be preserved upon power failure. This is called as MDI operation and the step follows:

- (1) Press mode selection key [Edit];
- (2) Select [Monitor], [MDI] in the menu to enter MDI interface;
- (3) Enter program block instruction manually;
- (4) Press [Start], [EOB] to start executing the program block.

5.3 USB disk DNC

The program read from external USB disk can operate the machine tool without saving in CNC memory. This operation is called as USB disk DNC operation.

The step of USB disk DNC operation follows:

- (1) Insert the USB disk;
- (2) Select [Monitor], [File] in the menu to enter file operation interface;
- (3) Select USB disk and press [EOB] to enter;
- (4) Move cursor to select a file in the disk;
- (5) Press [EOB] to load the file into work area (system buffer);
- (6) Press mode selection key [Auto];
- (7) Press the [Start] key to run the program, and the indicator is on.

Caution

The system won't record the USD disk path. If power failure occurs during DNC processing, the program info will be lost when the power supply is connected again.

5.4 Speed rate adjustment

Feeding rate

In automatic mode, press Up/Down key in [Position] interface to adjust the feeding rate; Press the key once to increase or decrease by 10% (10%-150%).

Manual rate

In manual mode, press Up/Down key in [Position] interface to adjust the manual rate; Press the key to increase or decrease by 10% (10%-150%). If you press the FF key and Up/Down key, you can adjust the fast forward rate by 10% (10%-150%).

Principal axis rotation

In automatic or manual mode, press the Left/Right key to adjust the principal axis rotation by 100r/min. The maximum rotation is set by the principal axis parameters in the system and the minimum rotation is 16r/min. If you press and hold the key for three seconds, the value will be increased or decreased quickly.

5.5 Run idle

(Reserved)

5.6 SBK function

In automatic mode, press [SBK] to start the SBK function. Current program block stops after executing; press [Start] again and next block stops after executing. The SBK mode allows checking the program block by block.

Caution:

- ① In G28-G30, single block also can be stopped at the center point;
- ② The stop points of single block in fixed circle are ①, ②, ⑥ in the figure below; when the single blocks of ①, ② stops, the feeding pauses and the pause indicator is on.

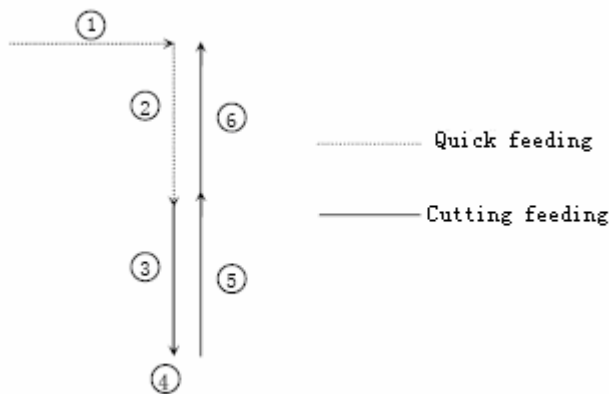

5.7 BDT function

In automatic mode, press [BDT] to start the BDT function, which will make the block instructions in the line after '/' in the program invalid.

5.8 Stopping automatic operating

Two methods are available to stop automatic operating, i.e. enter stop command where the program will stop (M00, M01) and press the key on the operation panel to stop the machine tool.

Program stops

After executing the block with M00 or M01, the automatic operating stops, which is same to single block stop, and all mode information is saved. Start with CNC and the automatic operation can be started again.

After processing a part, the automatic operation stops.

Program ends

After executing the block with M30, the automatic operating stops, changes into reset state, and returns to program start.

Feeding pause

During automatic operation, press the [Pause] key on the operation panel, the automatic operation pauses and the indicator is on; press [Start] again to continue operating the machine tool and the pause indicator is on.

Reset

During automatic operation, press the [Reset] key on the operation panel and the system stops immediately. Here, [Reset] has the same function as emergency stop button.

6. Safe operation

6.1 Emergency stop

Press the emergency stop button on the machine tool, which will stop immediately, and all outputs such as principal axis rotation and coolant are turned off. Rotate the button clockwise to cancel emergency stop, but all outputs must be restarted.

 **Caution:**

The power supply isn't always cut off upon emergency stop. Please refer to the electrical configuration description of the machine tool manufacturer for details;

Before releasing emergency stop, please eliminate the problems of the machine tool.

6.2 Hard limit over travel

The system alarms if the tool touches travel switch during operation. The axis in corresponding direction can't move, and only moves in reverse direction. Before the alarm is released, the system can't enter automatic operation normally. After investigating the alarm reason, press [Reset] to clear the alarm information.

6.3 Soft limit over travel

If the tool enters the restriction area regulated by the parameter (travel limit), the system alarms over travel, and the tool decelerates and stops. At this moment, you can move the tool to safe direction in manual mode, and then press [Reset] to release the alarm.

 **Caution:**

During automatic operation, when the tool touches an axial travel switch, the tool decelerates and stops all axial motions, and only displays one over travel alarm.

During manual operation, when the tool touches an axial travel switch, the tool only decelerates and stops motion on current axis, and still moves along other axes.

When the tool is in safe position, press [Reset] to clear the alarm. Please refer to the manual of the machine tool for details.

Both limit alarm and soft limit alarm have a deceleration stop, and therefore the sensing range of the limit should have sufficient space, or else the limit protection will be disabled due to over travel.

7. Alarm and self- diagnosis function

The system has several levels, and the alarm numbers also have different type, as follow:

- 0~1023: G code program running alarm info
 1024~2048: System environment alarm info

7.1 NC program execution alarm

0000	:	Reset
0001	:	Prog No End
0004	:	M6Tx Abort
0005	:	Tool Invalid
0006	:	G Program Repeat Error
0007	:	G Program Number Error
0008	:	G7X8X Instruction Run Error
0009	:	Program Abend
0010	:	Appointed M01 Instruction Stop
0011	:	M98 Format Error
0012	:	Motion Run Error
0013	:	Current Program No Repair
0014	:	G Program Format Error
0015	:	M99 Instruction Abort
0016	:	Motion Abort
0017	:	Illegal char
0018	:	Noneffective Exegesis Character
0019	:	Illegal G Code
0020	:	GCode RadialOffset Num Err
0021	:	Noneffective GCode RadialOffset
0022	:	Arc Appointed Error
0023	:	Appointed Noneffective Plane
0024	:	M98 Instruction Abort
0025	:	Spindle Appointed Number Error
0026	:	MCode Instruction Abort
0027	:	Spi Appointed Err
0028	:	Motion Repeat Request
0029	:	Appointed Arc Nonentity
0030	:	Missing X Code Error
0031	:	Missing X Code Error

0032	:	Missing X Code Error
0033	:	Missing X Code Error
0034	:	Missing X Code Error
0035	:	Missing X Code Error
0036	:	Missing X Code Error
0037	:	Missing X Code Error
0038	:	Missing X Code Error
0039	:	Missing X Code Error
0040	:	Missing X Code Error
0041	:	Missing X Code Error
0042	:	Missing X Code Error
0043	:	Missing X Code Error
0044	:	Missing X Code Error
0045	:	Missing X Code Error
0046	:	Missing X Code Error
0047	:	Missing X Code Error
0048	:	Screw Value Repeat Error
0049	:	System Abort
0050	:	Factitious return
0051	:	no parameter input
0052	:	no store address for Gcode pro num form

7.2 System environment alarm

1024	:	no \return zero\ 1. The system doesn't perform home action after started
1025	:	4 - direction program limit
1026	:	4 + direction program limit
1027	:	Z - direction program limit
1028	:	Z + direction program limit
1029	:	Y - direction program limit
1030	:	Y + direction program limit
1031	:	X - direction program limit
1032	:	X+ direction program limit

1033	:	4 - direction machine limit
1034	:	4 + direction machine limit
1035	:	Z - direction machine limit
1036	:	Z + direction machine limit
1037	:	Y - direction machine limit
1038	:	Y + direction machine limit
1039	:	X - direction machine limit
1040	:	X+ direction machine limit

The system has corresponding limit alarm. Please check corresponding limit sensor point or parameters. If hard limit occurs, and the appearance of the sensor point doesn't has any problem, enter the diagnosis mode in manual mode and check the state of the input port in diagnosis mode. If the state is valid, please eliminate in sequence. Pull out the input IO cable and check whether the sense disappears. If yes, please check the circuit. If the problem still exists, the internal optocoupler is broken. Please contact the supplier.

1041	:	Emergency stop
------	---	----------------

Emergency stop button of the handheld box interface is valid.

External emergency stop 2 input is valid; check whether IO assignment has conflict or interference. Search for corresponding function ports in IO configuration, and then check in input diagnosis.

1042	:	X Sevor driver alarm
1043	:	Y Sevor driver alarm
1044	:	Z Sevor driver alarm
1045	:	4 Sevor driver alarm

Servo alarm; if the servo doesn't alarm, parameter P2.001~004 setting and actual servo alarm level may be reverse. Please modify the parameters.

The corresponding function ports are IN34~37, which can be checked in input diagnosis.

1046	:	Axis's physical line redefine
------	---	-------------------------------

Interface axis No. set by parameter P2.45~P2.49 is specified repeatedly

1047	:	spi no to home
------	---	----------------

1048	:	workpiece no lock
------	---	-------------------

1049	:	safe signal can't detect
------	---	--------------------------

1051	:	air no enough
------	---	---------------

1052	:	chuck signal alarm detect
------	---	---------------------------

7.3 Alarm processing

- If alarm occurs, please refer to the alarm code to confirm the failure reason.
- When alarm occurs, if the system isn't reset, the alarm will constantly prompt no matter whether the alarm still exists, so as to avoid the conditions that false alarm causes system suspended, but can't find the reason.
- If the error is caused by data setting, modify the data, and then press [Reset] to clear the alarm info.

- When alarm occurs, please remove the alarm reason. Please note that several alarms may occur at the same time. Please refer to the alarm info in the Diagnosis menu for details. When the alarms are eliminated, please press [Reset] to clear the alarm ring.

7.4 Self-diagnosis function

The CNC system may stop even when there is no alarm info, this may be because the system is executing certain processes. Please check with the self-diagnosis function.

The step of self-diagnosis follows:

- (1) In the main menu, press [Diagnosis] to enter the diagnosis interface;
- (2) Select [Input] to enter the input diagnosis interface, or select [Output] to enter the output diagnosis interface;
- (3) Output diagnosis: In edit mode, press the direction keys to select the output port, and press [EOB] to switch the output level of corresponding output port;
- (4) Input diagnosis: When certain input signal is valid, the corresponding area on the screen flashes.

8. Program saving & editing

8.1 Saving the program in the memory

8.1.1 Keypad input (new program)

Create new program in the memory with the keypad, and the step follows:
In the main menu, press [Edit] to enter program edit interface;
Press [File] to enter file operation interface;
Select [New] to create a new file;
Enter the file name and press [EOB] to confirm and create a new program in current directory in the memory, and load into the system by default;
Select [Close] to exit [Edit] interface;
In edit mode, enter the program content;
After editing all programs, press [Reset] to save the edited programs into the system memory.

8.1.2 PC serial port input

The step of transmitting files to controller through PC follows:
Set system baud rate and ID No.;
Connect to PC and run Adtech serial communication software;
Set the baud rate same as controller, and scan ID device;
Select the [Upload file to NC] button in the communication software;
Select CNC file in the popup dialog box and press [Open] button.

8.1.3 Copying processing files from USB disk

The step of copying CNC processing file to system memory through USB disk follows:
In the main menu, press [Edit] to enter program edit interface;
Select [File] to enter file operation interface;
Select USB disk and press [EOB] to enter;
Move the cursor to select a CNC file and then select [Copy];
Return to the root directory, locate the PROG directory in disk D, enter the directory, and select [Paste] to complete copying.

8.2 Reading programs into work area

8.2.1 Reading programs from controller into work area

The step of loading files from system memory into work area follows:
Press [File] to enter file operation interface;
Select desired program, which is in PROG directory in disk D by default, press [EOB] to enter subdirectory, or press [Cancel] to exit;
Move cursor to select desired program, press [EOB] to confirm and load the program.

8.2.2 Reading programs from USB disk into work area

The step of loading files from USB disk into work area follows:
Insert the USB disk;
Press [File] to enter file operation interface;
Select USB disk, move cursor to select a file in the disk, and press [EOB] to load the file.

8.3 Editing & modifying programs

The program in CNC memory can be edited with NC keypad. In the main menu, press [Edit] to enter program edit interface and edit the program in current work area (for loading program into work area, refer to 8.2). The edit mode similar to

notepad in Windows. Move the cursor directly to locate, press keys to enter, press [EOB] to change line, and press [Delete] to delete the character where the cursor locates.

 **Caution**

After all operations, press Reset to save the files, and the functions base on edit mode;

CNC46XX uses new file mapping technology, and allows loading processing files that exceed its memory. Therefore, to ensure the system efficiency, you can only search and process, but can't edit the processing files that exceed 2MB.

8.4 Deleting files

8.4.1 Deleting files in memory

Follow the step below to delete the programs in system memory:

Press [File] to enter file operation interface;

Follow the prompt on the screen, select the file and press [Delete] to confirm and delete the file.

 **Caution**

If the program has been loaded into work area, you need to restart the system to delete the program, or else the system will report error.

The programs loaded into the work area can't be deleted, or else the system will report error.

9. Main interfaces of the system

9.1 Position interface

The position interface shows current machine tool coordinates, including absolute position, relative position and comprehensive position. In the main interface, press [Monitor] to enter the position interface.

To enter position interface:

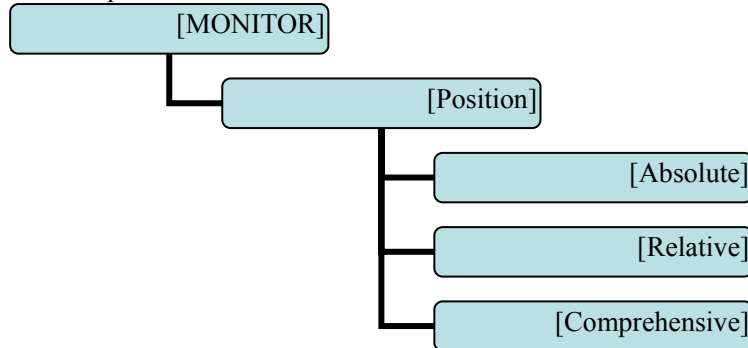

Absolute position

The position of current machine tool coordinates relative to the origin of workpiece coordinate system

The absolute position interface follows:

Abs pos		EDIT		Run		Edit		Param		Coord		Test	
X	+0000.000	M	05	X Speed	1000								
Y	+0000.000		09	Y Speed	1000								
Z	+0000.000		33	Z Speed	1000								
			11	A Speed	1000								
		T	0001	JOG rate	100%								
		S	100	SPI rate	100%								
G01 G17 G90 G54 G80		file name		0000.CNC		Prog		0001					
G40 :D00 = 000.000		00001 :		G01 Y2000 F50000 ;		M04 S1 ;		M89 P1 L1 ;		M89 P1 L0 ;		T0101 ;	
G49 :H00 = 000.000				T0101 ;				G01 X20 ;				T0102 ;	
sys time 09:19:11													
Stop													
close	Abs	Rel	All										>>>

Absolute Position Interface

Relative position

In manual mode, reset current coordinates to check the relative motion distance of any displacement, and thus it is called as relative position.

This interface is usually used for early tool setting. Considering that some operators have been used to manual calculation, this function is preserved. With the more and more powerful of automatic centered function, it is used less.

The operation follows:

- Enter [Position] interface;
- Switch to [Relative] interface;
- Then, enter manual mode;
- Press a coordinate axis No., e.g., ‘X’, and the X coordinate flashes;
- Press “Cancel” to reset X coordinate to 0;

The relative position interface follows:

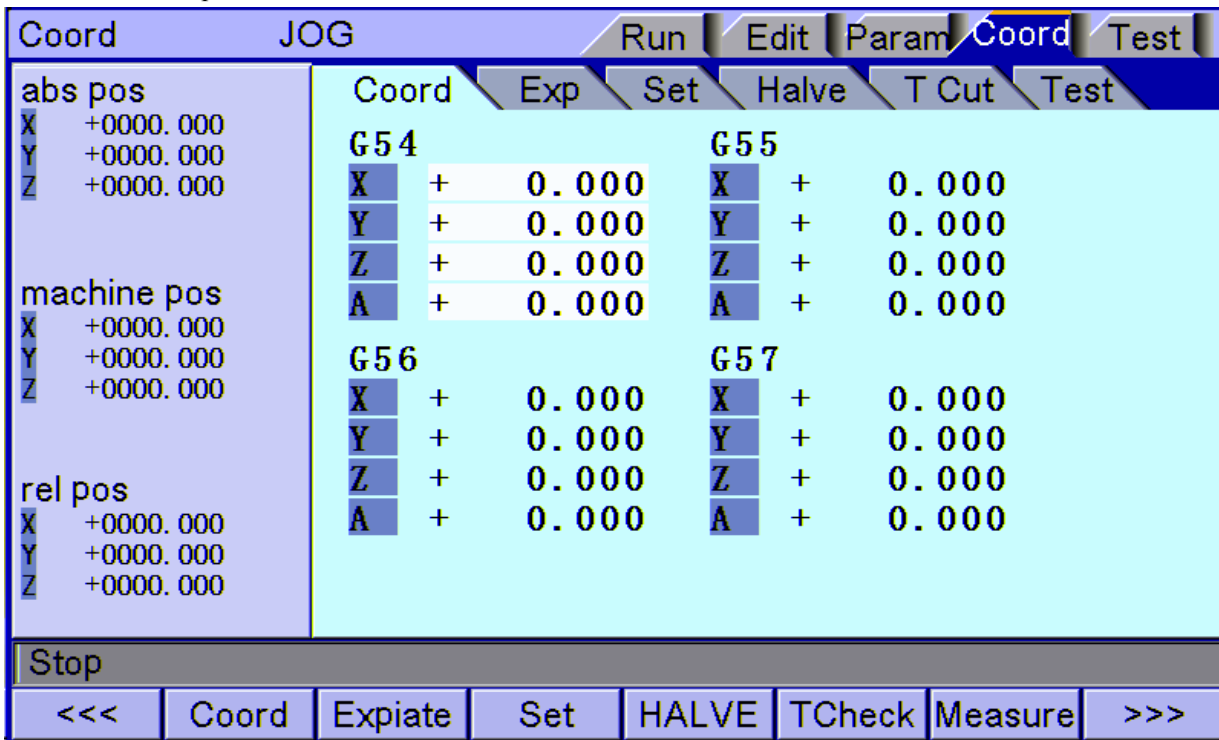

Relative Position Interface

Comprehensive coordinates

The interface displayed by absolute coordinates and machine tool coordinate Comprehensive position interface is shown below:

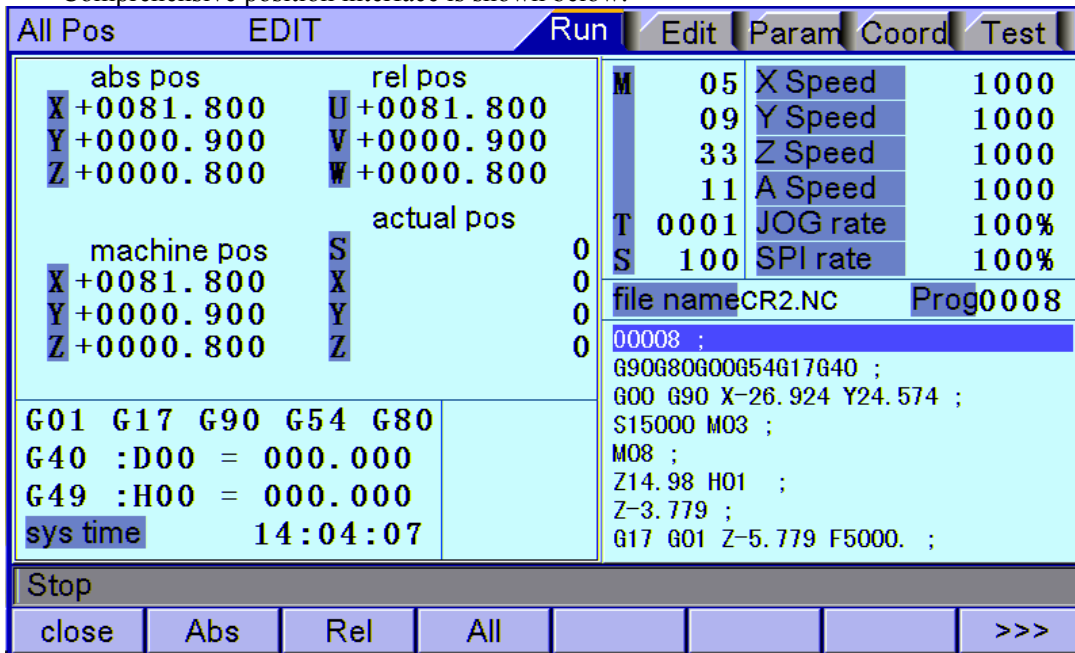

Comprehensive Position Interface

9.2 Edit interface

The edit interface shows the program info in current work area. In the main interface, press [Edit] to enter the program interface.

To enter program edit interface:



Program edit

The program edit interface shows the NC program currently processed; in edit mode, you can edit the NC program (see 8.3 for details).

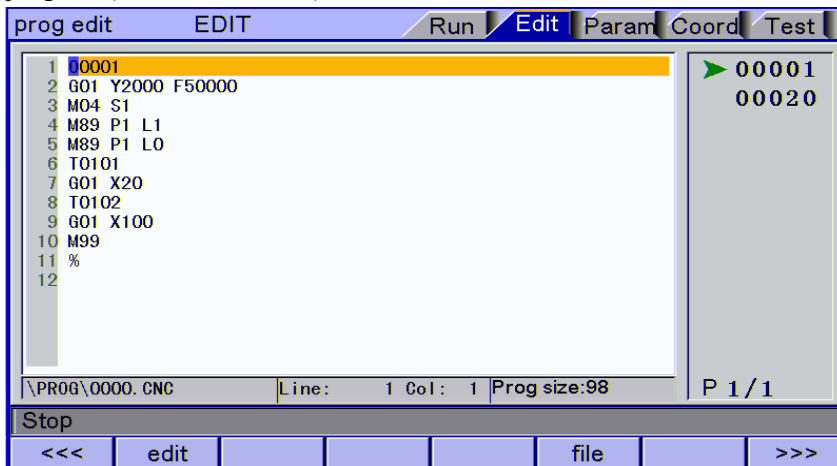

Program Edit Interface

System info interface

The system info is a summary of the program blocks in current processing area, and calculates the resource usage in current work area. The upper right of the program directory interface shows the version info of current controller software. If our engineering personnel asks to confirm the software version of the controller on site, please provide this version info.

To enter system info interface:

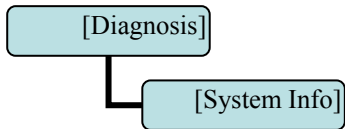

System info interface is shown below:

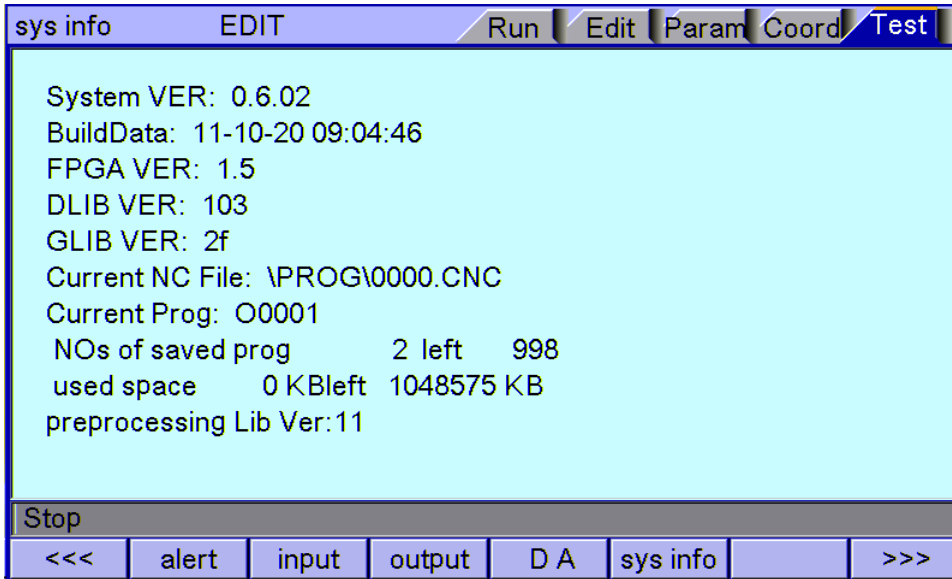

System Info Interface

9.3 MDI interface

MDI mode is mainly used for the execution of single G code in certain occasions.

To enter MDI interface:

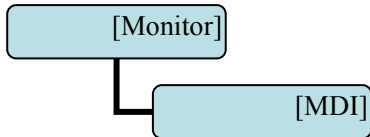

In MDI interface, enter complete NC code instruction in edit mode, press the [Start] key in the edit mode and confirm to execute directly.

To restore the default settings quickly, press and hold the [Reset] key for three seconds and choose to reset or not.

MDI interaction interface is shown below:

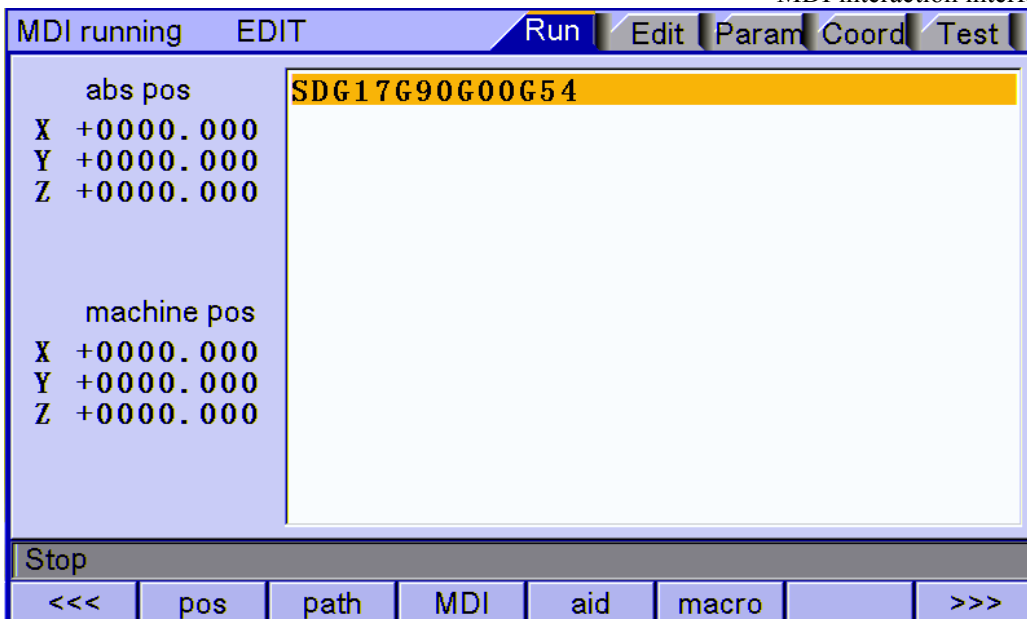

MDI Interface

9.4 File management

In the file management interface, you can manage the system files.

To enter file management interface:

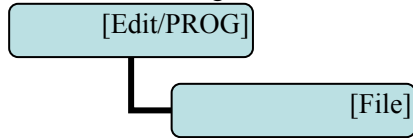

File management mainly has the following functions:

- Connect the UBS disk, and copy the files between USB disk and electronic disk;
- Upgrade system software: Copy the upgrade file to system memory in either method above to upgrade the software;
- Restart the controller. In [File Management] interface, press the Reset key to restart the controller. This method is different from restarting due to power failure. In certain occasions, you can restart the controller quickly in this method to make certain function take effect.
- Connect to PC with the USB cable, and exchange the data between USB disk and PC.

File operation interface is shown below:

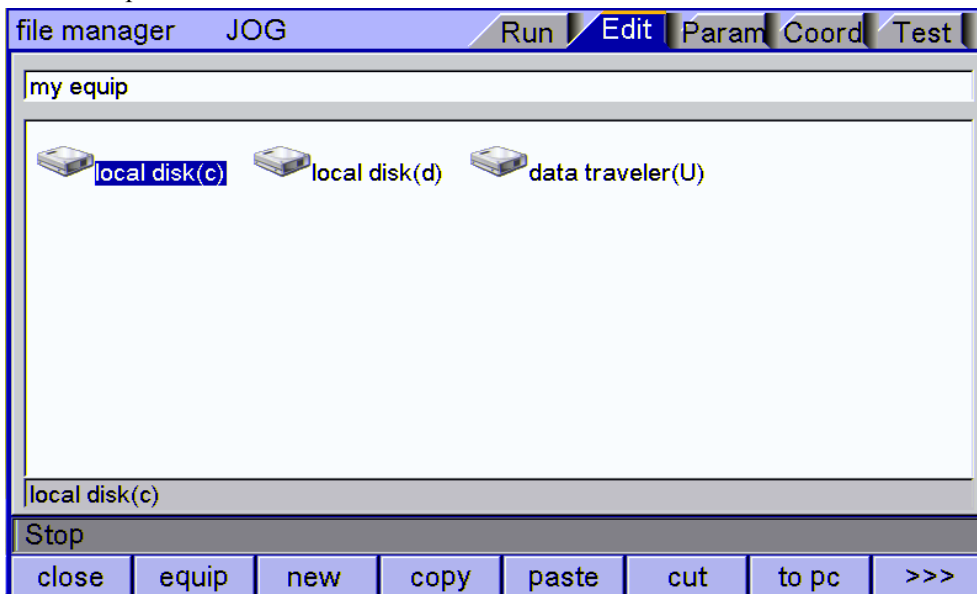

File Operation Interface

9.5 Graphic simulation

[Track] function is to simulate NC processing program.

To enter graphic simulation interface:

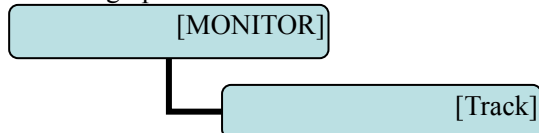

Enter track interface to enable real-time track display automatically. During automatic running of the system, the motion track is displayed in real-time. In standby mode, you can also press Preview to prescan the processing file.

The shortcuts of adjusting position:

PageUp: Zoom in

PageDown: Zoom out

→←↑↓: Shift position; the shift unit is the set pixel unit

Graphic simulation interface is shown below:

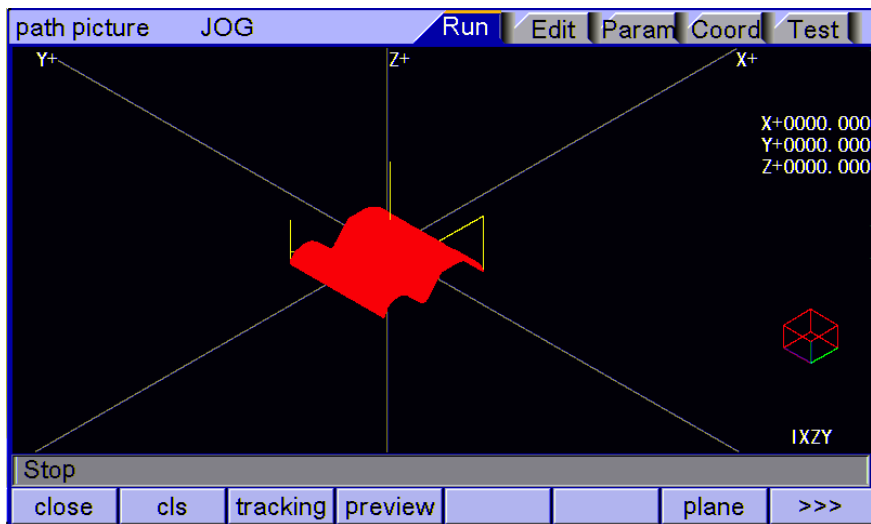

Graphic Simulation Interface

9.6 Parameter interface

The parameter interface shows system parameter info, including comprehensive, axis parameter, management, tool magazine, principal axis, port, etc. In the main interface, press [parameter] to enter the interface.

Parameter has the following menus:

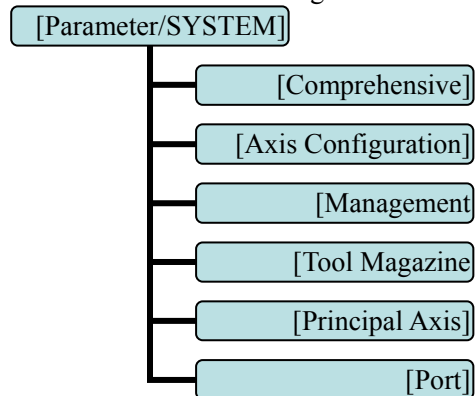

Comprehensive parameters

Comprehensive parameters are a set of functions that aren't classified in details, e.g. home mode, manual speed, etc.

Comprehensive parameter interface is shown below:

general		JOG		Run	Edit	Param	Coord	Test
001 X Gear Numerator	1	013,X StartupSpeed(mm/min)	100					
002 X Gear Denominator	1	014,Y StartupSpeed(mm/min)	100					
003 Y Gear Numerator	1	015,Z StartupSpeed(mm/min)	100					
004 Y Gear Denominator	1	016,4 StartupSpeed(mm/min)	100					
005 Z Gear Numerator	1	017,X Acceleration(Kpps)	1000					
006,Z Gear Denominator	1	018,Y Acceleration(Kpps)	1000					
007,4 Gear Numerator	1	019,Z Acceleration(Kpps)	1000					
008,4 Gear Denominator	1	020,4 Acceleration(Kpps)	1000					
009,X FastSpeed(mm/min)	3000	021,X Soft PosLimit+(mm)	+ 9999.999					
010,Y FastSpeed(mm/min)	3000	022,X Soft PosLimit-(mm)	- 9999.999					
011,Z FastSpeed(mm/min)	3000	023,Y Soft PosLimit+(mm)	+ 9999.999					
012,4 FastSpeed(mm/min)	3000	024,Y Soft PosLimit-(mm)	- 9999.999					
Stop								
<<<	genl	axis	manage	tools	spindle	port	>>>	

Comprehensive Parameter Interface

Axis parameters

Axis parameters are parameter set of interface characteristics of control position axis. Please refer to the parameter description for details.

Axis parameter interface is shown below:

axis		JOG		Run	Edit	Param	Coord	Test
001,X_ServoAlarmIn ELevel	0	013,Z_ECZ Home Enable	0					
002,Y_ServoAlarmIn ELevel	0	014,Z_ECZ Home ELevel	0					
003,Z_ServoAlarmIn ELevel	0	015,4_ECZ Home Enable	0					
004,A_ServoAlarmIn ELevel	0	016,4_ECZ Home ELevel	0					
005,X_ServoResetOut ELeve	1	017,X Limit+ Enable<●>	0					
006,Y_ServoResetOut ELeve	1	018,X Limit- Enable<●>	0					
007,Z_ServoResetOut ELeve	1	019,X Limit ELevel<●>	0					
008,A_ServoResetOut ELeve	1	020,Y Limit+ Enable<●>	0					
009,X_ECZ Home Enable	0	021,Y Limit- Enable<●>	0					
010,X_ECZ Home ELevel	0	022,Y Limit ELevel<●>	0					
011,Y_ECZ Home Enable	0	023,Z Limit+ Enable<●>	0					
012,Y_ECZ Home ELevel	0	024,Z Limit- Enable<●>	0					
Stop								
<<<	genl	axis	manage	tools	spindle	port	>>>	

Management parameters

This is a function set that confirms identity and initialize the system.

Management parameter interface is shown below:

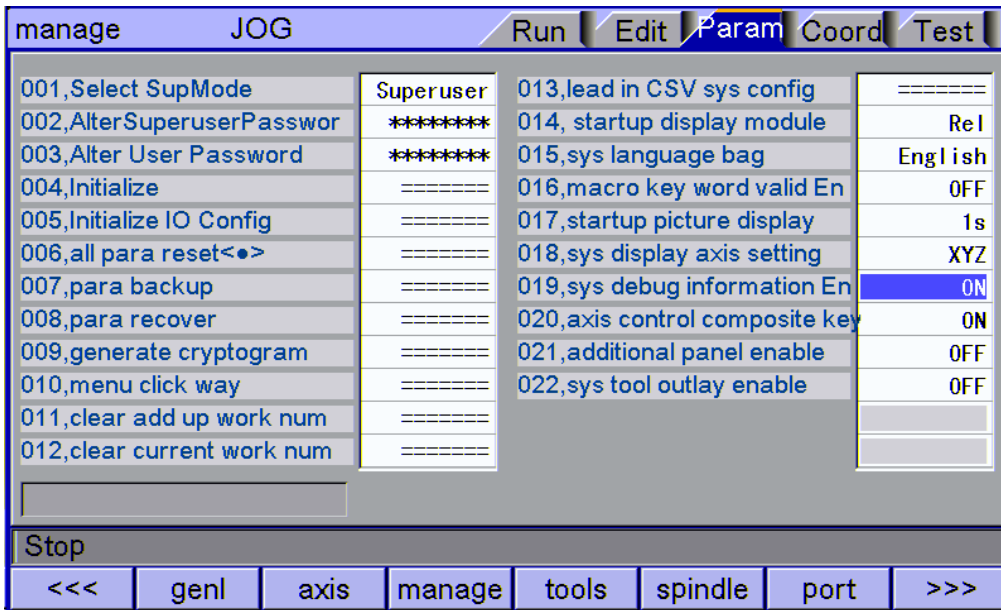

Management Parameter Interface

Tool magazine parameters

Tool magazine parameters collect the parameters that the tool magazine requires. The specific meaning of the parameters should be determined by the tool magazine of the machine tool, and therefore should refer to the instructions provided by the machine tool manufacturer.

Principal axis parameters

Principal axis parameters are the set of electrical characteristics of servo and common principal axes. The specific application also depends on the principal axis selection of the machine tool manufacturer. The servo parameters and axis parameters have the same meaning, and therefore please refer to the description of axis parameters.

Principal axis parameter interface is shown below:

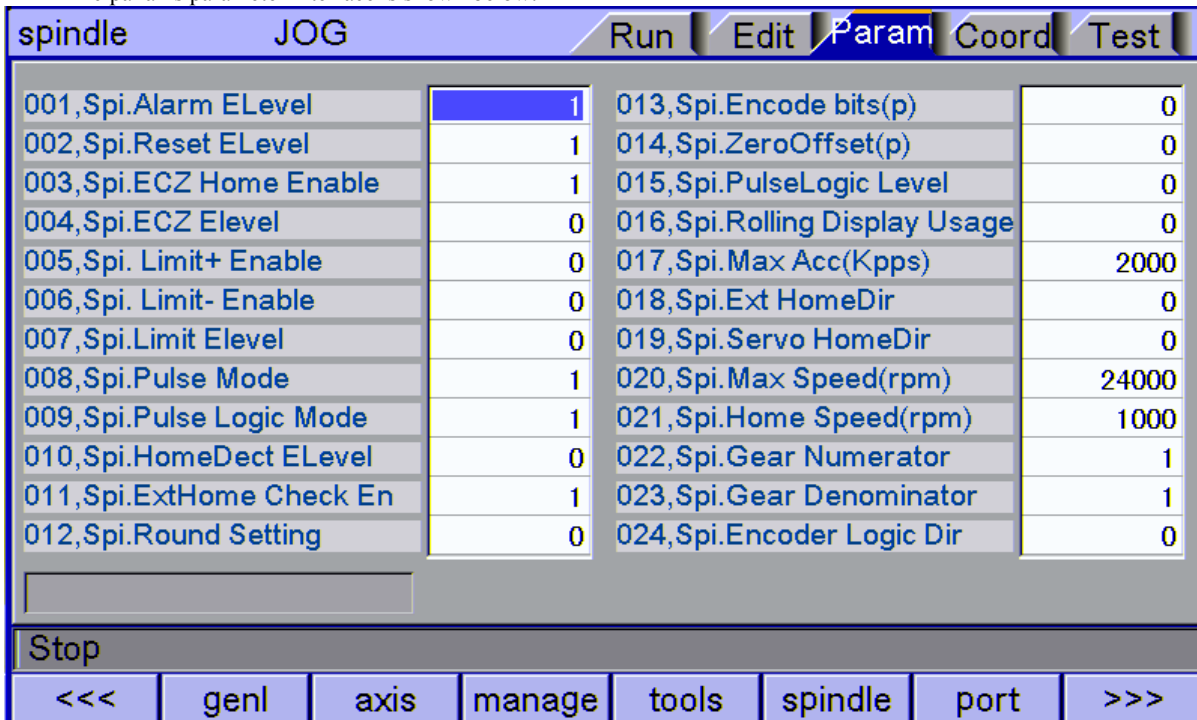

Principal Axis Parameters Interface

IO configuration parameters

IO configuration parameters are the assignment of hardware interfaces. This parameter set is the IO pin sequence specified by the system's IO function numbers, which will improve the system flexibility. Please refer to System Parameters for the specific meaning of the parameters.

IO configuration parameter interface is shown below:

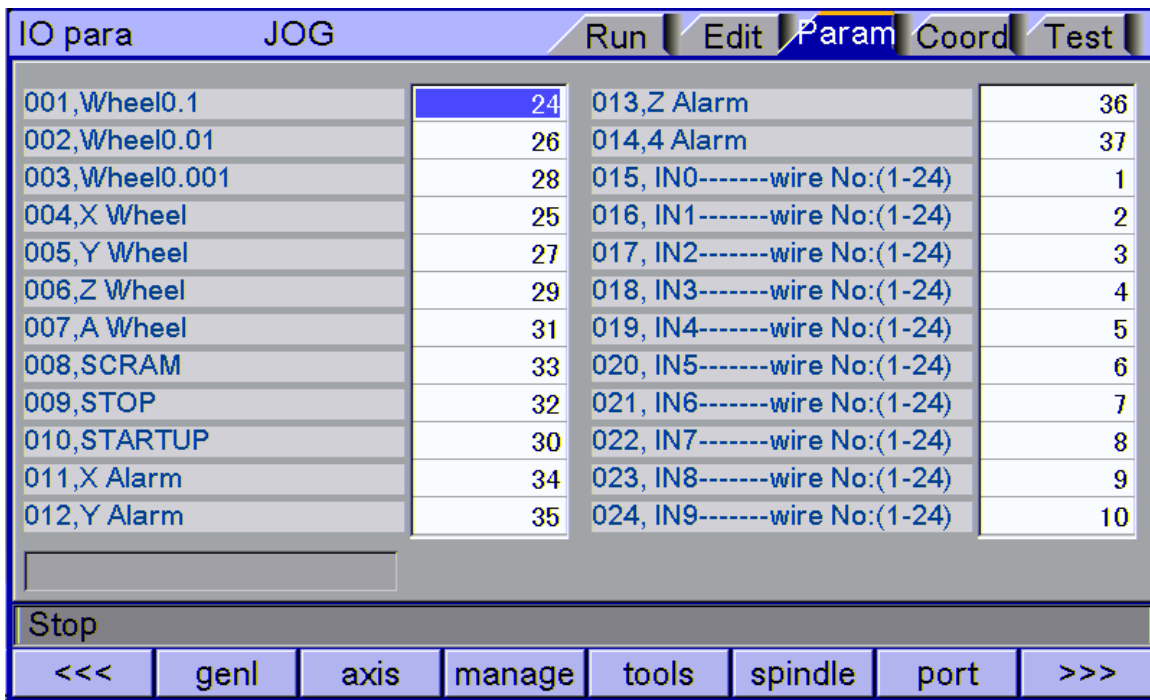

IO Configuration Parameters Interface

9.7 Compensation interface

Tool compensation interface shows tool compensation info of the system, including tool length compensation, tool radius compensation and other input variables. The compensation method is different from M series and L series, which will be described below.

To enter tool compensation interface:

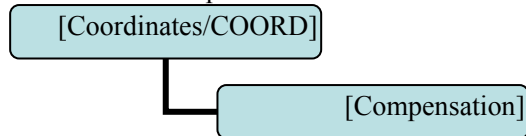

M series tool compensation interface has two compensation variables, i.e. tool length compensation and tool radius compensation; corresponding to G43, G44 and G41, G42; enter compensation value to corresponding compensation number, and transfer the compensation number in NC program to realize the compensation. Tool compensation numbers have 36 variables.

Tool compensation interface is shown below:

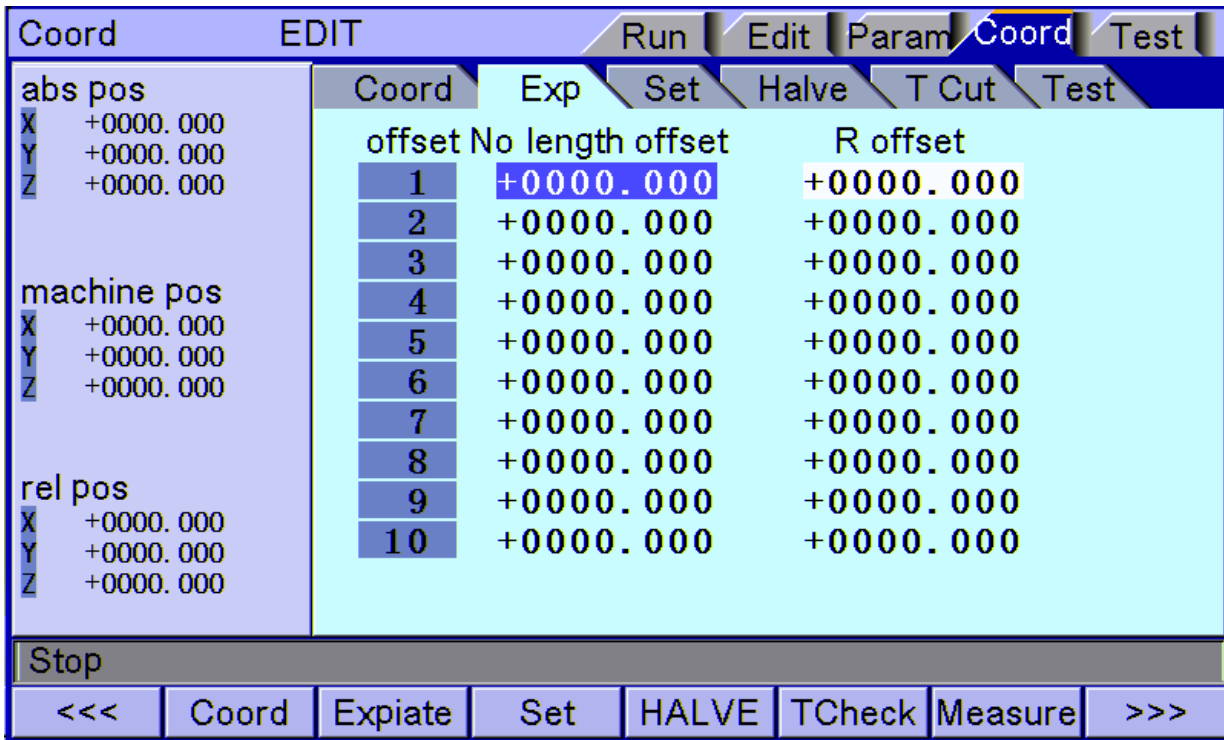

Tool Compensation Parameter Setting Interface

9.8 M series workpiece coordinate system setting interface

The coordinates interface shows coordinate system info, including setting, coordinate system, centered, and tool regulator. In the main interface, press [Coordinate] to enter coordinate system.

Workpiece coordinate system

Display workpiece coordinate system, i.e. the offset of workpiece home position and machine tool home position, Totally six basic workpiece coordinate systems (G54~G59) and nine extension coordinate systems (G591~G599) are available.

To enter workpiece coordinate system interface:

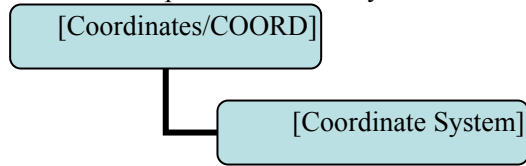

The workpiece coordinate system interface is shown below:

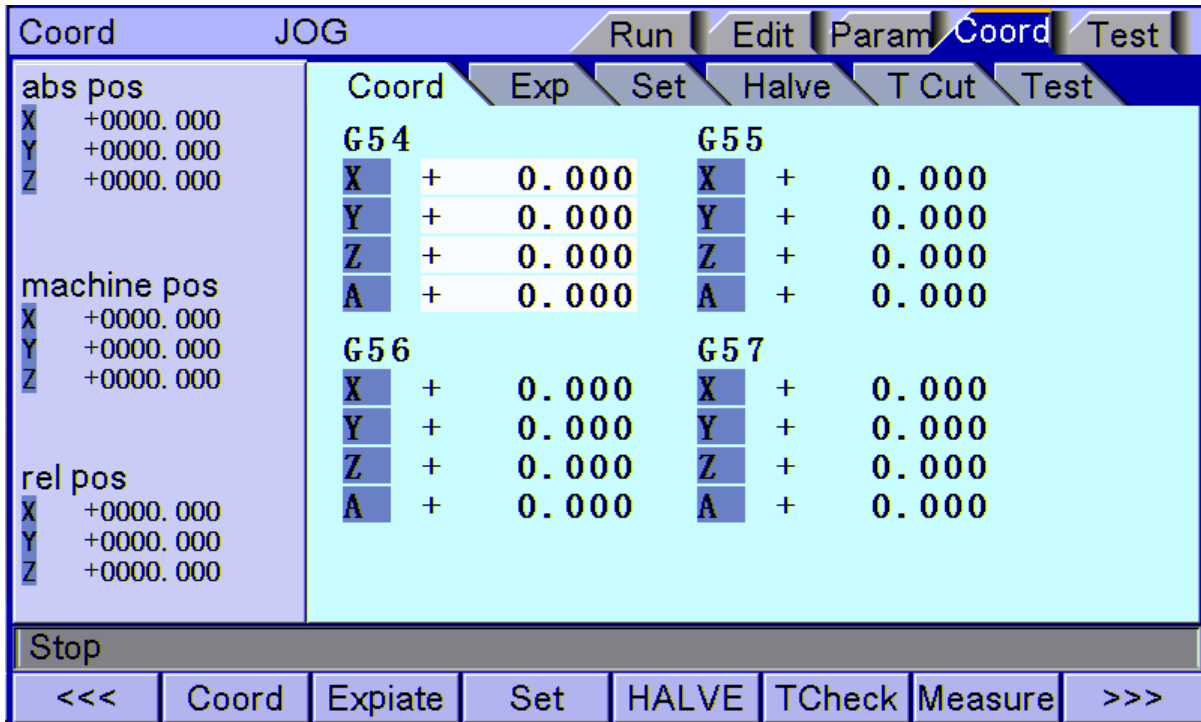

Workpiece Coordinate System Setting Interface

Coordinate system auxiliary parameter setting interface

The auxiliary parameters for workpiece coordinate system, including origin offset and tool setting parameters of automatic tool regulator.

To enter coordinate system auxiliary parameter setting interface:

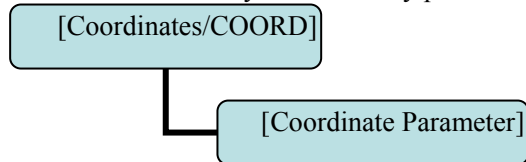

The detailed auxiliary parameters are described in the table below:

1	X coordinates offset
2	Y coordinates offset
3	Z coordinates offset
4	A coordinates offset
5	X coordinates of tool regulator
6	Y coordinates of tool regulator
7	Z coordinates of tool regulator
8	Axis selection symbol of tool regulator
9	Effective voltage level of tool regulator
10	Set tool automatically after changing
11	Tool regulator machine tool X limit
12	Tool regulator machine tool Y limit
13	Tool regulator machine tool Z limit
14	Tool regulator X search direction
15	Tool regulator Y search direction
16	Tool regulator Z search direction
17	Tool regulator limit effective signal
18	Add offset to coordinates automatically

(1) Origin offset

- The origin offset is added to current machine tool coordinates when setting the coordinate system; this parameter setting is available in next tool setting;
- The application of this parameter is for the processing of certain parts that require several working procedures. The first processing procedure may damage the tool setting position of the workpiece, and the next procedure can't locate the proper tool setting position. Therefore, a reference tool setting point is required, and the offset from reference point to actual tool setting position can be set to this parameter. No matter tool setting in which procedure, you only need to set to this reference point and it is same like setting to home position of the workpiece.

(2) Tool regulator coordinates, effective signal, automatic tool setting, machine tool Z negative limit of tool regulator:

- The X, Y coordinates are the mechanical coordinates of the tool regulator on machine tool; the tool regulator can position automatically only when the coordinate is set properly.
- Effective voltage level of tool regulator is to set the signal interface level of the tool regulator, which should be set according to the actual interface of the tool regulator.
- Automatic tool setting after changing is that the tool regulator function executes automatically after tool changing instruction is returned successfully to improve the processing efficiency.
- Z negative limit is used to prevent crash caused by not in place of Z axis error checking. Once negative limit alarm occurs, the tool regulator stops working immediately. If the system is in processing state, the system will send abnormal alarm; during separate setting of the tool regulator, the alarm won't occur.

9.9 Controller diagnosis interface (diagnosis)

The diagnosis interface is used to display the hardware interfaces and system info, including alarm, input, output, DA diagnosis; press [Diagnosis] to enter the diagnosis interface.

The diagnosis interface follows:

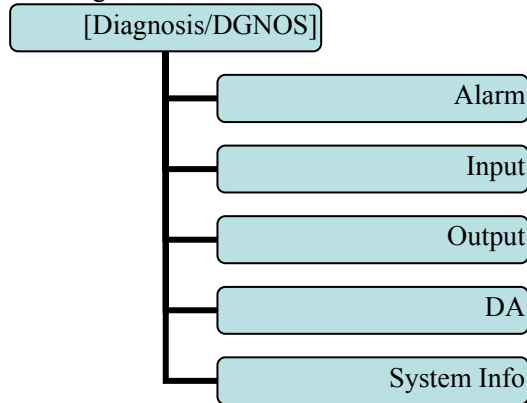

Alarm interface

Display the alarm of the system after power on, including 15 alarm records.

IO diagnosis interface

IO diagnosis allows entering at any moment. You can check current IO state of the system. In manual mode, press the direction keys to select corresponding IO, and press EOB to control the output manually.

DA diagnosis interface

Correct the output voltage of two lines DA voltage module for testing; press the direction keys to output corresponding voltage directly, input the actually measured voltage to corresponding gear position; when transferring control instructions of principal axis, the system will correct according to correction value.

System info

The system info shows basic information of current system, and is used to mark current software version, hardware version, upgrade info, etc. In this interface, you can follow the prompt to perform operations.

9.10 Macro variable view interface (macro variable)

This is the variable register view menu of macro function. In this menu, you can turn pages to view the macro variables, or enter values to variable register directly in edit mode.

To enter macro variable view interface:

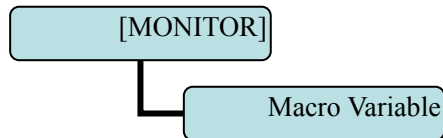

The macro variable menu has eight levels, as below:

Local variable

#100~#199

#500~#599

#600~#699

#700~#799

#800~#899

#900~#999

Process variable

- In the variable interfaces of different levels, you can check the corresponding variable number. Local variable has five levels totally, and shows the variables of current working layer by default. To view a specific layer, please enter local variable submenu, and then select according to layers.

- Process variables are to customize the names of 20 variables (#100~#999) according to CSV configuration table, so that the variable names have visual meanings. In programs, the user customized variables are transferred with variable number.

9.11 Current mode instruction info

Display the G code mode info of current system;

In [Monitor] interface, you can check the running code info of current system:

Motion instruction:	G00, G01
Select plane:	G17, G18, G19
Coordinate logic:	G90, G91
Workpiece coordinate system:	G54, G59, G591...G599
Radius compensation:	G40, G41, G42
Length compensation:	G43, G44, G49
Compound instruction retracting plane:	G98, G99
Principal axis rotation:	S
Tool No.:	T

10. System maintenance

10.1 Restart

- (1) In the main menu, press [Edit] to enter the program interface;
- (2) Press [File] to enter the file interface;
- (3) Press [Reset] and the system asks whether restart or not;
- (4) Press [OK] to restart the system.

10.2 System upgrade

The step of copying upgrade program with USB disk follows:

- (1) In the main menu, press [Edit] to enter the program interface;
- (2) Press [File] to enter the file management interface;
- (3) Insert the USB disk, select the USB disk symbol in the root directory; after reading successfully, the system enters the USB directory automatically;
- (4) Move cursor to the upgrade file ADTROM.BIN, select [Copy], enter ADT directory in disk D and paste;
- (5) Select the second upgrade file NC_RES.NC; skip this step if the file doesn't exist. Also select Copy, enter disk D, and paste in directory ADT.
- (6) After upgrading, enter BIOS, select USB in [Boot-up mode], and restart the system to take effect.
- (7) Enter System Info in Diagnosis menu to view the system version and compilation date, and check whether the upgrade is successful.

10.3 Reset

- (1) Select the edit mode;
- (2) In the main menu, press [Parameter] to enter the parameter interface;
- (3) Press [Management] key to enter management parameter interface;
- (4) Move cursor to "006 Reset all parameters";
- (5) Press [EOB], the system confirms, restores the default parameters and restarts automatically.

10.4 Parameter backup and restore

- (1) Select the edit mode;
- (2) In the main menu, press [Parameter] to enter the parameter interface;
- (3) Press [Management] key to enter management parameter interface;
- (4) Move cursor to 007 or 008, and select corresponding operation menu;
- (5) Press [EOB], the system confirms, and performs backup or restore operation;
- (6) The backup operation will generate the SYSCONF.BAK file in the root directory of disk D. Please save this file for backup in the future.
- (7) For restore operation, also save the SYSCONF.BAK file in the root directory of disk D. The system will recognize this file automatically in the process of restoring.

10.5 Entering BIOS

- (1) If the system has irreversible error and can't be started, please enter BIOS to upgrade and maintain the program;
- (2) To enter BIOS, press the [Cancel] key after the controller is electrified and before the application is started; after entering, a blue background interface pops up. If the BIOS requires password, a prompt pops up. Please type the password to enter the BIOS.
- (3) Enter BIOS to perform operations such as format disk C, D, and copy files from USB disk to upgrade;

11. System parameters

According to occasions and functions, the parameters contain comprehensive parameters, IO configuration parameters, management parameters and coordinate setting parameters.

- Comprehensive parameters are complete, and contain basic operation and usage settings of the controller, including principal axis, handwheel, home, tool magazine, etc.;
- IO configuration parameters are mainly used for machine installation and test, adapting to the interface characteristics of machine tool and motor drive;
- Coordinate setting parameters are tool setting configuration in [Coordinate] interface;

(1) It is required to confirm user identity to modify the parameter table. The controller has two levels of user authority, which are super user and operator; super user can modify all parameters and user passwords; while operator only can operate the parameters that require modification, and modify the operator password; in P3.1 of management parameters, the system enters the corresponding mode automatically according to the entered password.

(2) According to the application, the parameters will take effect immediately or after restarted; the parameters that require restart are marked with <●>.

(3) Certain parameters are set in binary system (parameter descriptor has bit symbol); the conversion between binary system and decimal system follows:

- Bit0: Set to 1 to correspond to decimal 1;
- Bit1: Set to 1 to correspond to decimal 2;
- Bit2: Set to 1 to correspond to decimal 4;
- Bit3: Set to 1 to correspond to decimal 8;
- Bit4: Set to 1 to correspond to decimal 16;
- Bit5: Set to 1 to correspond to decimal 32;
- Bit6: Set to 1 to correspond to decimal 64;
- Bit7: Set to 1 to correspond to decimal 128;

For more bits, multiply the decimal system corresponding to binary system of previous position by 2. If only the corresponding bit is 1, accumulate the numbers of corresponding decimal system according to the comparison table to get the setting value.

For example: set Bit0, Bit1 and Bit5 to 1, and the parameter will be $1+2+32=35$.

11.1 Parameter index list

Parameter type	S/N	Description	Effective mode	Default value	Page
General parameter (P1.)	001	X Gear Numerator	Instant		
General parameter (P1.)	002	X Gear Denominator	Instant		
General parameter (P1.)	003	Y Gear Numerator	Instant		
General parameter (P1.)	004	Y Gear Denominator	Instant		
General parameter (P1.)	005	Z Gear Numerator	Instant		
General parameter (P1.)	006	Z Gear Denominator	Instant		
General parameter (P1.)	007	4 Gear Numerator	Instant		
General parameter (P1.)	008	4 Gear Denominator	Instant		
General parameter (P1.)	009	X FastSpeed(mm/min)	Instant		
General parameter (P1.)	010	Y FastSpeed(mm/min)	Instant		
General parameter (P1.)	011	Z FastSpeed(mm/min)	Instant		
General parameter (P1.)	012	4 FastSpeed(mm/min)	Instant		
General parameter (P1.)	013	XStartupSpeed(mm/min)	Instant		
General parameter (P1.)	014	YstartupSpeed(mm/min)	Instant		
General parameter (P1.)	015	ZstartupSpeed(mm/min)	Instant		
General parameter (P1.)	016	4StartupSpeed(mm/min)	Instant		

Parameter type	S/N	Description	Effective mode	Default value	Page
General parameter (P1.)	017	X Acceleration(Kpps)	Instant		
General parameter (P1.)	018	Y Acceleration(Kpps)	Instant		
General parameter (P1.)	019	Z Acceleration(Kpps)	Instant		
General parameter (P1.)	020	4 Acceleration(Kpps)	Instant		
General parameter (P1.)	021	X Soft PosLimit+(mm)	Instant		
General parameter (P1.)	022	X Soft PosLimit-(mm)	Instant		
General parameter (P1.)	023	Y Soft PosLimit+(mm)	Instant		
General parameter (P1.)	024	Y Soft PosLimit-(mm)	Instant		
General parameter (P1.)	025	Z Soft PosLimit+(mm)	Instant		
General parameter (P1.)	026	Z Soft PosLimit-(mm)	Instant		
General parameter (P1.)	027	4 Soft PosLimit+(mm)	Instant		
General parameter (P1.)	028	4 Soft PosLimit-(mm)	Instant		
General parameter (P1.)	029	Inp Speed(mm/min)	Instant		
General parameter (P1.)	030	InpStartSpeed(mm/min)	Instant		
General parameter (P1.)	031	InpAcceleration(mm/sec)	Instant		
General parameter (P1.)	032	XBacklashExpiate(pulse)	Instant		
General parameter (P1.)	033	YBacklashExpiate(pulse)	Instant		
General parameter (P1.)	034	ZBacklashExpiate(pulse)	Instant		
General parameter (P1.)	035	4BacklashExpiate(pulse)	Instant		
General parameter (P1.)	036	ZeroReturn Mode	Instant		
General parameter (P1.)	037	IO FilterWave(1~8)	Instant		
General parameter (P1.)	038	JOG Speed(mm/min)	Instant		
General parameter (P1.)	039	MaxFeedSpeed(mm/min)	Instant		
General parameter (P1.)	040	MaxMPGSpeed(mm/min)	Instant		
General parameter (P1.)	041	Wheel Coefficient	Instant		
General parameter (P1.)	042	M Code Delaytime(ms)	Instant		
General parameter (P1.)	043	X HOME Offset(pulse)	Instant		
General parameter (P1.)	044	Y HOME Offset(pulse)	Instant		
General parameter (P1.)	045	Z HOME Offset(pulse)	Instant		
General parameter (P1.)	046	4 HOME Offset(pulse)	Instant		
General parameter (P1.)	047	Line number	Instant		
General parameter (P1.)	048	System Baudrate	Instant		
General parameter (P1.)	049	Controler ID	Instant		
General parameter (P1.)	050	X HomeDir	Instant		
General parameter (P1.)	051	Y HomeDir	Instant		
General parameter (P1.)	052	Z HomeDir	Instant		
General parameter (P1.)	053	4 HomeDir	Instant		
General parameter (P1.)	054	Circle InpUnit(mm)	Instant		
General parameter (P1.)	055	G73(M)LoopObligate(mm)	Instant		
General parameter (P1.)	056	G83(M)LoopObligate(mm)	Instant		

Parameter type	S/N	Description	Effective mode	Default value	Page
General parameter (P1.)	057	ArcSpeedUpVal	Instant		
General parameter (P1.)	058	interpolation speed mode	Instant		
General parameter (P1.)	059	GCode pre-treatment	Instant		
General parameter (P1.)	060	'O'Pro Scan	Instant		
General parameter (P1.)	061	SpindleControlMode	Instant		
General parameter (P1.)	062	X ZeroReturn Speed	Instant		
General parameter (P1.)	063	Y ZeroReturn Speed	Instant		
General parameter (P1.)	064	Z ZeroReturn Speed	Instant		
General parameter (P1.)	065	4 ZeroReturn Speed	Instant		
General parameter (P1.)	066	Safe Signal ELevel	Instant		
General parameter (P1.)	067	Pressure Signal ELevel	Instant		
General parameter (P1.)	068	ChuckSignal ELevel	Instant		
General parameter (P1.)	069	OilPressure Open(min)	Instant		
General parameter (P1.)	070	OilPressure Keep(sec)	Instant		
General parameter (P1.)	071	OilPressureOut Freq(Hz)	Instant		
General parameter (P1.)	072	OilInspect ELevel	Instant		
General parameter (P1.)	073	SpindleAlarm ELevel	Instant		
General parameter (P1.)	074	TransducerAlarm ELevel	Instant		
General parameter (P1.)	075	ExScram ELevel	Instant		
General parameter (P1.)	076	BackHome ModeConf(bit)	Instant		
General parameter (P1.)	077	Arc Acc.for Radii	Instant		
General parameter (P1.)	078	Arc Acc.for Speed	Instant		
General parameter (P1.)	079	PretreatmentCode Set	Instant		
General parameter (P1.)	080	Inp AccSpeed Mode	Instant		
General parameter (P1.)	081	'S'Speed Acceleration	Instant		
General parameter (P1.)	082	ExStart ELevel	Instant		
General parameter (P1.)	083	ExPause ELevel	Instant		
General parameter (P1.)	084	HOME Check for alarm	Instant		
General parameter (P1.)	085	HOME Check Enable	Instant		
General parameter (P1.)	086	X diameter prog enable	Instant		
General parameter (P1.)	087	default process plane	Instant		
General parameter (P1.)	088	T code form	Instant		
General parameter (P1.)	089	IP address	Restart		
General parameter (P1.)	090	subnet mask	Restart		
General parameter (P1.)	091	default gateway	Restart		
General parameter (P1.)	092	Pretreatment segments	Instant		
General parameter (P1.)	093	feed speed setting En	Instant		
General parameter (P1.)	094	enable of G00 Inp mode	Instant		
Axis parameter (P2.)	001	X_ServoAlarmIn ELevel	Instant		

Parameter type	S/N	Description	Effective mode	Default value	Page
Axis parameter (P2.)	002	Y_ServoAlarmIn ELevel	Instant		
Axis parameter (P2.)	003	Z_ServoAlarmIn ELevel	Instant		
Axis parameter (P2.)	004	A_ServoAlarmIn ELevel	Instant		
Axis parameter (P2.)	005	X_ServoResetOut ELevel	Instant		
Axis parameter (P2.)	006	Y_ServoResetOut ELevel	Instant		
Axis parameter (P2.)	007	Z_ServoResetOut ELevel	Instant		
Axis parameter (P2.)	008	A_ServoResetOut ELevel	Instant		
Axis parameter (P2.)	009	X_ECZ Home Enable	Instant		
Axis parameter (P2.)	010	X_ECZ Home ELevel	Instant		
Axis parameter (P2.)	011	Y_ECZ Home Enable	Instant		
Axis parameter (P2.)	012	Y_ECZ Home ELevel	Instant		
Axis parameter (P2.)	013	Z_ECZ Home Enable	Instant		
Axis parameter (P2.)	014	Z_ECZ Home ELevel	Instant		
Axis parameter (P2.)	015	4_ECZ Home Enable	Instant		
Axis parameter (P2.)	016	4_ECZ Home ELevel	Instant		
Axis parameter (P2.)	017	X Limit+ Enable<●>	Instant		
Axis parameter (P2.)	018	X Limit- Enable<●>	Instant		
Axis parameter (P2.)	019	X Limit ELevel<●>	Instant		
Axis parameter (P2.)	020	Y Limit+ Enable<●>	Instant		
Axis parameter (P2.)	021	Y Limit- Enable<●>	Instant		
Axis parameter (P2.)	022	Y Limit ELevel<●>	Instant		
Axis parameter (P2.)	023	Z Limit+ Enable<●>	Instant		
Axis parameter (P2.)	024	Z Limit- Enable<●>	Instant		
Axis parameter (P2.)	025	Z Limit ELevel<●>	Instant		
Axis parameter (P2.)	026	4 Limit+ Enable<●>	Instant		
Axis parameter (P2.)	027	4 Limit- Enable<●>	Instant		
Axis parameter (P2.)	028	4 Limit ELevel<●>	Instant		
Axis parameter (P2.)	029	X Pulse Mode<●>	Instant		
Axis parameter (P2.)	030	Y Pulse Mode<●>	Instant		
Axis parameter (P2.)	031	Z Pulse Mode<●>	Instant		
Axis parameter (P2.)	032	4 Pulse Mode<●>	Instant		
Axis parameter (P2.)	033	X Pulse Dir Mode<●>	Instant		
Axis parameter (P2.)	034	Y Pulse Dir Mode<●>	Instant		
Axis parameter (P2.)	035	Z Pulse Dir Mode<●>	Instant		
Axis parameter (P2.)	036	4 Pulse Dir Mode<●>	Instant		
Axis parameter (P2.)	037	X Ext Home ELevel	Instant		
Axis parameter (P2.)	038	Y Ext Home ELevel	Instant		
Axis parameter (P2.)	039	Z Ext Home ELevel	Instant		
Axis parameter (P2.)	040	A Ext Home ELevel	Instant		
Axis parameter (P2.)	041	X Round Setting	Instant		

Parameter type	S/N	Description	Effective mode	Default value	Page
Axis parameter (P2.)	042	Y Round Setting	Instant		
Axis parameter (P2.)	043	Z Round Setting	Instant		
Axis parameter (P2.)	044	4 Round Setting	Instant		
Axis parameter (P2.)	045	X physial Assign Num<●>	Instant		
Axis parameter (P2.)	046	Y physial Assign Num<●>	Instant		
Axis parameter (P2.)	047	Z physial Assign Num<●>	Instant		
Axis parameter (P2.)	048	4 physial Assign Num<●>	Instant		
Axis parameter (P2.)	049	spindle physial Assign Num<●>	Instant		
Axis parameter (P2.)	050	X Encoder bit(p)	Instant		
Axis parameter (P2.)	051	Y Encoder bit(p)	Instant		
Axis parameter (P2.)	052	Z Encoder bit(p)	Instant		
Axis parameter (P2.)	053	4 Encoder bit(p)	Instant		
Axis parameter (P2.)	054	X Reset to 360	Instant		
Axis parameter (P2.)	055	Y Reset to 360	Instant		
Axis parameter (P2.)	056	Z Reset to 360	Instant		
Axis parameter (P2.)	057	4 Reset to 360	Instant		
Axis parameter (P2.)	058	X PulseLogic Level<●>	Instant		
Axis parameter (P2.)	059	Y PulseLogic Level<●>	Instant		
Axis parameter (P2.)	060	Z PulseLogic Level<●>	Instant		
Axis parameter (P2.)	061	4 PulseLogic Level<●>	Instant		
Axis parameter (P2.)	062	X feature(Rotate0 Line1)	Instant		
Axis parameter (P2.)	063	Y feature(Rotate0 Line1)	Instant		
Axis parameter (P2.)	064	Z feature(Rotate0 Line1)	Instant		
Axis parameter (P2.)	065	4 feature(Rotate0 Line1)	Instant		
Axis parameter (P2.)	066	X Rolling Display Usage	Instant		
Axis parameter (P2.)	067	Y Rolling Display Usage	Instant		
Axis parameter (P2.)	068	Z Rolling Display Usage	Instant		
Axis parameter (P2.)	069	4 Rolling Display Usage	Instant		
Axis parameter (P2.)	070	X Rolling Path Optimize	Instant		
Axis parameter (P2.)	071	Rolling Path Optimize	Instant		
Axis parameter (P2.)	072	Z Rolling Path Optimize	Instant		
Axis parameter (P2.)	073	4 Rolling Path Optimize	Instant		
Axis parameter (P2.)	074	Max Acc of X(Kpps)	Instant		
Axis parameter (P2.)	075	Max Acc of Y(Kpps)	Instant		
Axis parameter (P2.)	076	Max Acc of Z(Kpps)	Instant		
Axis parameter (P2.)	077	Max Acc of 4(Kpps)	Instant		
Axis parameter (P2.)	078	X Servo Home Dir	Instant		
Axis parameter (P2.)	079	Y Servo Home Dir	Instant		
Axis parameter (P2.)	080	Z Servo Home Dir	Instant		
Axis parameter (P2.)	081	A Servo Home Dir	Instant		

Parameter type	S/N	Description	Effective mode	Default value	Page
Axis parameter (P2.)	082	X Ext Home Eanble	Instant		
Axis parameter (P2.)	083	Y Ext Home Eanble	Instant		
Axis parameter (P2.)	084	Z Ext Home Eanble	Instant		
Axis parameter (P2.)	085	4 Ext Home Eanble	Instant		
Axis parameter (P2.)	086	X Encoder LogicDir<●>	Instant		
Axis parameter (P2.)	087	Y Encoder LogicDir<●>	Instant		
Axis parameter (P2.)	088	Z Encoder LogicDir<●>	Instant		
Axis parameter (P2.)	089	4 Encoder LogicDir<●>	Instant		
Axis parameter (P2.)	090	X HomeSpeed2	Instant		
Axis parameter (P2.)	091	Y HomeSpeed2	Instant		
Axis parameter (P2.)	092	Z HomeSpeed2	Instant		
Axis parameter (P2.)	093	4 HomeSpeed2	Instant		
Axis parameter (P2.)	094	X HomeSpeed3	Instant		
Axis parameter (P2.)	095	Y HomeSpeed3	Instant		
Axis parameter (P2.)	096	Z HomeSpeed3	Instant		
Axis parameter (P2.)	097	4 HomeSpeed3	Instant		
Axis parameter (P2.)	098	rotation axis opt feature	Instant		
Axis parameter (P2.)	099	4 axis max rotate speed	Instant		
Axis parameter (P2.)	100	hand wheel encoder dir	Instant		
Axis parameter (P2.)	101	X restrain acc (mm/s ²)	Instant		
Axis parameter (P2.)	102	Y restrain acc (mm/s ²)	Instant		
Axis parameter (P2.)	103	Z restrain acc (mm/s ²)	Instant		
Axis parameter (P2.)	104	4 restrain acc (mm/s ²)	Instant		
Axis parameter (P2.)	105	X max restrain rate	Instant		
Axis parameter (P2.)	105	Y max restrain rate	Instant		
Axis parameter (P2.)	105	Z max restrain rate	Instant		
Axis parameter (P2.)	105	4 max restrain rate	Instant		
Management parameter (P3.)	001	Select SupMode	Instant		
Management parameter (P3.)	002	AlterSuperuserPasswor	Instant		
Management parameter (P3.)	003	Alter User Password	Instant		
Management parameter (P3.)	004	Initialize	Restart		
Management parameter (P3.)	005	Initialize IO Config	Restart		
Management parameter (P3.)	006	all para reset<●>	Restart		
Management parameter (P3.)	007	para backup	Instant		
Management parameter (P3.)	008	para recover	Restart		
Management parameter (P3.)	009	generate cryptogram	Instant		
Management parameter (P3.)	010	menu click way	Instant		
Management parameter (P3.)	011	clear add up work num	Instant		

Parameter type	S/N	Description	Effective mode	Default value	Page
Management parameter (P3.)	012	clear current work num	Instant		
Management parameter (P3.)	013	lead in CSV sys config	Restart		
Management parameter (P3.)	014	startup display module	Restart		
Management parameter (P3.)	015	sys language bag	Restart		
Management parameter (P3.)	016	macro key word valid En	Instant		
Management parameter (P3.)	017	startup picture display	Instant		
Management parameter (P3.)	018	sys display axis setting	Instant		
Management parameter (P3.)	019	sys debug information En	Instant		
Management parameter (P3.)	020	axis control composite	Instant		
Management parameter (P3.)	021	additional panel enable	Instant		
Management parameter (P3.)	022	sys tool outlay enable	Instant		
Tool magazine parameter (P4.)		spindle	Instant		
Principal axis parameter (P5.)	001	Spi.Alarm ELevel	Instant		
Principal axis parameter (P5.)	002	Spi.Reset ELevel	Instant		
Principal axis parameter (P5.)	003	Spi.ECZ Home Enable	Instant		
Principal axis parameter (P5.)	004	Spi.ECZ Elevel	Instant		
Principal axis parameter (P5.)	005	Spi. Limit+ Enable	Instant		
Principal axis parameter (P5.)	006	Spi. Limit- Enable	Instant		
Principal axis parameter (P5.)	007	Spi.Limit Elevel	Instant		
Principal axis parameter (P5.)	008	Spi.Pulse Mode	Instant		
Principal axis parameter (P5.)	009	Spi.Pulse Logic Mode	Instant		
Principal axis parameter (P5.)	010	Spi.HomeDect ELevel	Instant		
Principal axis parameter (P5.)	011	Spi.ExtHome Check En	Instant		
Principal axis parameter (P5.)	012	Spi.Round Setting	Instant		
Principal axis parameter (P5.)	013	Spi.Encode bits(p)	Instant		
Principal axis parameter (P5.)	014	Spi.ZeroOffset(p)	Instant		
Principal axis parameter (P5.)	015	PulseLogic Level	Instant		
Principal axis parameter (P5.)	016	Rolling Display Usage	Instant		
Principal axis parameter (P5.)	017	Spi.Max Acc(Kpps)	Instant		
Principal axis parameter (P5.)	018	Spi.Ext HomeDir	Instant		
Principal axis parameter (P5.)	019	Spi.Servo HomeDir	Instant		
Principal axis parameter (P5.)	020	Spi.Max Speed(rpm)	Instant		
Principal axis parameter (P5.)	021	Spi.Home Speed(rpm)	Instant		
Principal axis parameter (P5.)	022	Spi.Gear Numerator	Instant		
Principal axis parameter (P5.)	023	Spi.Gear Denominator	Instant		
Principal axis parameter (P5.)	024	Spi.Encoder Logic Dir	Instant		
Principal axis parameter (P5.)	025	Spi.OpenDelayTime(ms)	Instant		

Parameter type	S/N	Description	Effective mode	Default value	Page
Port parameter (P6.)	001	Wheel0.1	Instant		
Port parameter (P6.)	002	Wheel0.01	Instant		
Port parameter (P6.)	003	Wheel0.001	Instant		
Port parameter (P6.)	004	X Wheel	Instant		
Port parameter (P6.)	005	Y Wheel	Instant		
Port parameter (P6.)	006	Z Wheel	Instant		
Port parameter (P6.)	007	A Wheel	Instant		
Port parameter (P6.)	008	SCRAM	Instant		
Port parameter (P6.)	009	STOP	Instant		
Port parameter (P6.)	010	STARTUP	Instant		
Port parameter (P6.)	011	X Alarm	Instant		
Port parameter (P6.)	012	Y Alarm	Instant		
Port parameter (P6.)	013	Z Alarm	Instant		
Port parameter (P6.)	014	4 Alarm	Instant		
Port parameter (P6.)	015	IN0-----wire No:(1-24)	Instant		
Port parameter (P6.)	016	IN1-----wire No:(1-24)	Instant		
Port parameter (P6.)	017	IN2-----wire No:(1-24)	Instant		
Port parameter (P6.)	018	IN3-----wire No:(1-24)	Instant		
Port parameter (P6.)	019	IN4-----wire No:(1-24)	Instant		
Port parameter (P6.)	020	IN5-----wire No:(1-24)	Instant		
Port parameter (P6.)	021	IN6-----wire No:(1-24)	Instant		
Port parameter (P6.)	022	IN7-----wire No:(1-24)	Instant		
Port parameter (P6.)	023	IN8-----wire No:(1-24)	Instant		
Port parameter (P6.)	024	IN9-----wire No:(1-24)	Instant		
Port parameter (P6.)	025	IN10-----wire No:(1-24)	Instant		
Port parameter (P6.)	026	IN11-----wire No:(1-24)	Instant		
Port parameter (P6.)	027	IN12-----wire No:(1-24)	Instant		
Port parameter (P6.)	028	IN13-----wire No:(1-24)	Instant		
Port parameter (P6.)	029	IN14-----wire No:(1-24)	Instant		
Port parameter (P6.)	030	IN15-----wire No:(1-24)	Instant		
Port parameter (P6.)	031	IN16-----wire No:(1-24)	Instant		
Port parameter (P6.)	032	IN17-----wire No:(1-24)	Instant		
Port parameter (P6.)	033	IN18-----wire No:(1-24)	Instant		
Port parameter (P6.)	034	IN19-----wire No:(1-24)	Instant		
Port parameter (P6.)	035	IN20-----wire No:(1-24)	Instant		
Port parameter (P6.)	036	IN21-----wire No:(1-24)	Instant		
Port parameter (P6.)	037	IN22-----wire No:(1-24)	Instant		
Port parameter (P6.)	038	IN23-----wire No:(1-24)	Instant		
Port parameter (P6.)	039	OUT0-----wire No:(1-24)	Instant		
Port parameter (P6.)	040	OUT1-----wire No:(1-24)	Instant		

Parameter type	S/N	Description	Effective mode	Default value	Page
Port parameter (P6.)	041	OUT2-----wire No:(1-24)	Instant		
Port parameter (P6.)	042	OUT3-----wire No:(1-24)	Instant		
Port parameter (P6.)	043	OUT4-----wire No:(1-24)	Instant		
Port parameter (P6.)	044	OUT5-----wire No:(1-24)	Instant		
Port parameter (P6.)	045	OUT6-----wire No:(1-24)	Instant		
Port parameter (P6.)	046	OUT7-----wire No:(1-24)	Instant		
Port parameter (P6.)	047	OUT8-----wire No:(1-24)	Instant		
Port parameter (P6.)	048	OUT9-----wire No:(1-24)	Instant		
Port parameter (P6.)	049	OUT10-----wire No:(1-24)	Instant		
Port parameter (P6.)	050	OUT11-----wire No:(1-24)	Instant		
Port parameter (P6.)	051	OUT12-----wire No:(1-24)	Instant		
Port parameter (P6.)	052	OUT13-----wire No:(1-24)	Instant		
Port parameter (P6.)	053	OUT14-----wire No:(1-24)	Instant		
Port parameter (P6.)	054	OUT15-----wire No:(1-24)	Instant		
Port parameter (P6.)	055	OUT16-----wire No:(1-24)	Instant		
Port parameter (P6.)	056	OUT17-----wire No:(1-24)	Instant		
Port parameter (P6.)	057	OUT18-----wire No:(1-24)	Instant		
Port parameter (P6.)	058	OUT19-----wire No:(1-24)	Instant		
Port parameter (P6.)	059	OUT20-----wire No:(1-24)	Instant		
Port parameter (P6.)	060	OUT21-----wire No:(1-24)	Instant		
Port parameter (P6.)	061	OUT22-----wire No:(1-24)	Instant		
Port parameter (P6.)	062	OUT23-----wire No:(1-24)	Instant		
Port parameter (P6.)	063	Safe Signal	Instant		
Port parameter (P6.)	064	PressureDect Port	Instant		
Port parameter (P6.)	065	ChuckDectect Port	Instant		
Port parameter (P6.)	066	SysOilOut Port	Instant		
Port parameter (P6.)	067	TChecking signal Port	Instant		
Port parameter (P6.)	068	AlarmLight Out Port	Instant		
Port parameter (P6.)	069	RunLight Out Port	Instant		
Port parameter (P6.)	070	VFD 0 Level Out Port	Instant		
Port parameter (P6.)	071	VFD 1 Level Out Port	Instant		
Port parameter (P6.)	072	VFD 2 Level Out Port	Instant		
Port parameter (P6.)	073	VFD 3 Level Out Port	Instant		
Port parameter (P6.)	074	Oiling Out Port	Instant		
Port parameter (P6.)	075	Cooler Out Port	Instant		
Port parameter (P6.)	076	Spindle CW Out Port	Instant		
Port parameter (P6.)	077	Spindle CCW Out Port	Instant		
Port parameter (P6.)	078	System OilDect Port	Instant		
Port parameter (P6.)	079	SpindleAlarm DetectPort	Instant		
Port parameter (P6.)	080	Transduser DetectPort	Instant		

Parameter type	S/N	Description	Effective mode	Default value	Page
Port parameter (P6.)	081	ExScram2 DetectPort	Instant		
Port parameter (P6.)	082	Air of ToolCheck OutPort	Instant		
Port parameter (P6.)	083	IO Conf in RESET 00~15	Instant		
Port parameter (P6.)	084	IO Conf in RESET 16~23	Instant		
Port parameter (P6.)	085	ExStart2 DetectPort	Instant		
Port parameter (P6.)	086	ExPause2 DetectPort	Instant		
Port parameter (P6.)	087	TCheck Limit DetectPort	Instant		

11.2 Comprehensive parameters (P1.)

001	X Gear Numerator
002	X Gear Denominator
003	Y Gear Numerator
004	Y Gear Denominator
005	Z Gear Numerator
006	Z Gear Denominator
007	4 Gear Numerator
008	4 Gear Denominator

Range : 1~65535
 Unit : None
 Authority : Operation admin or higher
 Default : 1
 Effective time : Instant
 Note : When screws of different pitches and motors of different step angles or servo motors of different pulses are matched, or connected through gears, it allows keeping the program and actual motion distance consistent through electronic gear ratio setting of the system.
 $CMR/CMD = P / (L \times 1000)$
 CMR: gear ratio numerator
 CMD: gear ratio denominator
 P: Pulses corresponding to one rotation of the motor
 L: Machine tool movement corresponding to one rotation of the motor (mm)
 CMD/CMR is the pulse equivalent actually, i.e. the motion distance corresponding to every pulse (unit: 0.001mm).
 Ex 1: the motor rotates one cycle every 5000 pulses, and the machine tool moves 5mm when the motor rotates one cycle, then
 $CMR/CMD = 5000 / (5 \times 1000) = 1/1$
 Then, CMR=1, CMD=1, the pulse equivalent is 0.001mm
 Ex 2: the motor rotates one cycle every 5000 pulses, and the machine tool moves 10mm when the motor rotates one cycle, then
 $CMR/CMD = 5000 / (10 \times 1000) = 1/2$
 Then, CMR=1, CMD=2, the pulse equivalent is 0.002mm

009	X FastSpeed(mm/min)
010	FastSpeed(mm/min)
011	Z FastSpeed(mm/min)
012	4 FastSpeed(mm/min)
013	XStartupSpeed(mm/min)
014	YStartupSpeed(mm/min)
015	ZStartupSpeed(mm/min)
016	4StartupSpeed(mm/min)
017	X Acceleration(Kpps)
018	Y Acceleration(Kpps)
019	Z Acceleration(Kpps)
020	4 Acceleration(Kpps)

Range : 1~9999, 1~9999, 1~8000
 Unit : mm/min,mm/min,mm/sec
 Authority : Operation admin or higher
 Default : 3000,200,1500
 Effective time : Instant
 Note : This parameter is the trapezoid acceleration/deceleration setting and used for GOO instruction
 About start speed, 1-2 rotation motor speed is recommended for step motor; as above, the machine tool moves 5mm when the motor rotates one cycle, and the speed is 5-10mm/sec (300-600mm/min). For servo motor, the start and stop shouldn't have vibration. If this speed is too high, it will cause vibration during motion, and the step motor will be out of step.
 The acceleration and start speed also affect manual speed, home speed, etc.;

021	X Soft PosLimit+(mm)
022	X Soft PosLimit-(mm)
023	Y Soft PosLimit+(mm)
024	Y Soft PosLimit-(mm)
025	Z Soft PosLimit+(mm)
026	Z Soft PosLimit-(mm)
027	4 Soft PosLimit+(mm)
028	4 Soft PosLimit-(mm)

Range : -9999~9999
 Unit : mm
 Authority : Operation admin or higher
 Default : Maximum positive/negative value
 Effective time : Instant
 Note : Generally, the machine tool has hard limit signal. In this case, software limit isn't required. Please set the positive limit to +9999.999, and negative limit to -9999.999.
 If hard limit switch isn't installed, please use soft limit, which uses machine tool coordinate system as the base point. Positive limit and negative limit are subject to actual distance (unit: mm).
 Since soft limit decelerates and stops at the limit point, it may exceed the set distance, which depends on acceleration time and speed. Please keep certain margin when setting this parameter.

029	Inp Speed(mm/min)
030	InpStartSpeed(mm/min)
031	InpAcceleration(mm/sec)
039	XBacklashExpiate(pulse)
	Range : 1~9999, 1~9999, 1~8000, 1~9999 Unit : mm/min,mm/min,mm/sec,mm/min Authority : Operation admin or higher Default : 3000,200,1000,3000 Effective time : Instant Note : The feeding instructions such as G01, G02 and G03 move at the speed of F instruction. If the F instruction isn't specified in the program, the above instructions move at the speed set by this parameter. If the F instruction is specified, this parameter will be invalid. The maximum feeding speed restricts the F instruction during processing, i.e. no matter what F is set to, the actual speed can't exceed this parameter value. Setting this parameter will prevent the damage caused by accidental speed programming error when transferring processing files.
032	XBacklashExpiate(pulse)
033	YBacklashExpiate(pulse)
034	ZBacklashExpiate(pulse)
035	4BacklashExpiate(pulse)
	Range : 1~20000 Unit : Pulse Authority : Operation admin or higher Default : 0 Effective time : Instant Note : Compensate the clearance between control axis Compensate with the pulse in minimum unit. The specific number should be converted according to gear ratio.
036	ZeroReturn Mode
	Range : 0~1 Unit : None Authority : Operation admin or higher Default : 0 (program) Effective time : Instant Note : 0 - Program home 1 - Mechanical home Program home is that the coordinates go to home, i.e. in place. Mechanical home requires external detection switch to locate the home position; while home operation, move to specified home direction at home speed, and move back slowly after signal is detected. At this moment, move forward slowly when the signal is disconnected, and the home operation completes when the signal is valid again. When the servo Z phase enable switch in IO configuration parameters is enabled, mechanical home will enable Z phase positioning as home position automatically after signal reaches.
037	IO FilterWave(1~8)
	Range : 0~8 Unit : None Authority : Super Admin Default : 0 Effective time : After restarted Note : Set the filter constant; If the environment has too much interference, e.g. rain and thunder, please enter a filter value. Higher value indicates longer test time and high reliability; 0 indicates no filter;

038	JOG Speed(mm/min)
041	Wheel Coefficient
	Range : 1~9999 Unit : mm/min Authority : Operation admin or higher Default : 1000, 9000 Effective time : Instant Note : Set manual speed and handwheel speed; The start speed and acceleration in this mode are determined by 013, 014, 015, 016, 017, 018, 019, 020;
042	M Code Delaytime(ms)
	Range : 1~9999 Unit : ms Authority : Operation admin or higher Default : 100 Effective time : Instant Note : Set the waiting time (unit: ms) after executing M code
043	X HOME Offset(pulse)
044	Y HOME Offset(pulse)
045	Z HOME Offset(pulse)
046	4 HOME Offset(pulse)
	Range : -9999~9999 Unit : Pulse Authority : Operation admin or higher Default : 0 Effective time : Instant Note : Set the compensation home offset (unit: pulse) after axis home operation. First, complete the mechanical home operation, offset corresponding pulse, and then set this point as mechanical home. Note: This parameter is invalid during program home operation.
047	Line number
	Range : 0~64 Unit : None Authority : Operation admin or higher Default : 0 Effective time : Instant Note : While editing G code manually, add a line number Nxxxxx automatically in a new line; 0 indicates that this function is disabled;
048	System Baudrate
	Range : 9600~115200 Unit : None Authority : Operation admin or higher Default : 115200 Effective time : Restart Note : The communication rate setting when DNC or other PC software and this controller are in RS232 communication mode

049	Controler ID
	Range : 1~255 Unit : None Authority : Operation admin or higher Default : 1 Effective time : Restart Note : The ID number setting of the controller when DNC or other PC software and this controller are in MODBUS communication mode
050	X HomeDir
051	Y HomeDir
052	Z HomeDir
053	4 HomeDir
	Range : 0~1 Unit : None Authority : Operation admin or higher Default : 1, 1, 0, 0 Effective time : Instant Note : Set the mechanical home direction of every processing axis Positive Negative
054	Circle InpUnit(mm)
	Range : 0~1 Unit : mm Authority : Operation admin or higher Default : 0.2 Effective time : Instant Note : Set the arc interpolation equivalent If this value is too small, the arc has higher approximation accuracy, but the computation will be too high, making the pause during processing obvious and affecting the processing effect.
055	G73(M)LoopObligate(mm)
056	G83(M)LoopObligate(mm)
	Range : 0.1~100 Unit : mm Authority : Operation admin or higher Default : 2.000 Effective time : Instant Note : Set the tool retracting amount after Q is fed in G73 and G83 instructions; this parameter (default: 2mm) is set according to actual chip removal effect.
057	ArcSpeedUpVal
	Range : 10~500 Unit : mm/sec Authority : Operation admin or higher Default : 100 Effective time : Instant Note : Set arc acceleration equivalent If this value is too small, the acceleration will be slow; please select a higher value according to the arc size.
058	interpolation speed mode
	Range : 0~1 Unit : None Authority : Operation admin or higher Default : 0 (acceleration)

	Effective time : Instant
	Note : In pretreatment mode, set to 0 to use corner speed balancing algorithm, or set to 1 to use axis acceleration constraints balancing algorithm
059	GCode pre-treatment
	Range : 0~1
	Unit : None
	Authority : Operation admin or higher
	Default : 0 (real-time processing)
	Effective time : Instant
	Note : Real-time processing is suitable for machine test. In pretreatment mode, the system enters processing state buffs for two seconds and pre-reads. The pretreatment mode only can check the direction and size of feeding segment to adjust the speed automatically and process at optimized speed.
060	'O'Pro Scan
	Range : 0~1
	Unit : None
	Authority : Operation admin or higher
	Default : 1
	Effective time : Instant
	Note : File scanning symbol will quicken the file transfer speed when processing large files. When transferring NC files, the system needs to scan over to position every program block. In this way, if the file only has one block and the file size is very big, it will cause unnecessary waiting time. If this option is closed, the system will exit after scanning the address of first block.
061	SpindleControlMode
	Range : 0~1
	Unit : None
	Authority : Operation admin or higher
	Default : 0
	Effective time : Instant
	Note : Control mode corresponding to principal axis S code (frequency conversion mode) 0: Analog output 1: Section speed regulation (4-digit code), as below: OUT23-----S0 OUT22-----S1 OUT21-----S2 OUT20-----S3 In analog output mode, the analog voltage is: $V=S/MaxRPM$ S is the rotation set by the user, and MaxRPM is the maximum rotation of principal axis set by the parameter (P4.017); In switching quantity mode, constitute block 0-15 according to four-digit code to output; S code value is restricted to 0-15;
062	X ZeroReturn Speed
063	Y ZeroReturn Speed
064	Z ZeroReturn Speed
065	4 ZeroReturn Speed
	Range : 0~9999
	Unit : mm/min
	Authority : Operation admin or higher
	Default : 1000
	Effective time : Instant
	Note : Set the home speed of every axis separately
066	Safe Signal ELevel
	Range : 0~1

Unit : LOGIC VOLTAGE LEVEL
 Authority : Operation admin or higher
 Default : 0
 Effective time : Instant
 Note : Set the effective voltage level of the system safety signal. The source of safety signal can be customized by the user, and generally may be electric cabinet door and similar sensitive occasions. If there are several insecure places, please connect the signals in parallel to safety signal test pin of the system.
 Considering the convenience of maintenance, safety signals are checked only when the system starts processing, and won't prompt in idle state.

067	Pressure Signal ELevel
-----	------------------------

Range : 0~1
 Unit : LOGIC VOLTAGE LEVEL
 Authority : Operation admin or higher
 Default : 0
 Effective time : Instant
 Note : Set the effective voltage level of system air pressure alarm
 Both air pressure alarm and emergency stop alarm are effective globally.

073	SpindleAlarm ELevel
-----	---------------------

074	TransduserAlarm ELevel
-----	------------------------

068	ChuckSignal ELevel
-----	--------------------

Range : 0~1
 Unit : LOGIC VOLTAGE LEVEL
 Authority : Operation admin or higher
 Default : 0
 Effective time : Instant
 Note : The above alarms are checked while the system is running. The system alarms once the test is valid.
 This port is affected by IO configuration.

069	OilPressure Open(min)
-----	-----------------------

070	OilPressure Keep(sec)
-----	-----------------------

071	OilPressureOut Freq(Hz)
-----	-------------------------

Range :
 Unit :
 Authority : Operation admin or higher
 Default : 0
 Effective time : Instant
 Note : Set the schedule start and holding time of the automatic oil pump of the system
 Schedule open setting is that the oil pump outputs (OUT10) when the timing reaches specified value after the system starts and times.
 Output signal stops keeping for the seconds specified by P1.070 (reverse phase).
 Output signal follows the hertz specified by P1.071 in working state, and used for oil supply devices. If it is set to 0, the system will keep low output level.

072	OilInspect ELevel
-----	-------------------

Range : 0~1
 Unit : LOGIC VOLTAGE LEVEL
 Authority : Operation admin or higher
 Default : 0
 Effective time : Instant
 Note : Lubricant pressure test is performed automatically when the lubricant output of the system completes.
 The system alarms immediately if no oil pressure in place signal is detected after lubricant output.
 This port is affected by IO configuration.

075	ExScram ELevel
082	ExStart ELevel
083	ExPause ELevel
	Range : 0~1 Unit : LOGIC VOLTAGE LEVEL Authority : Operation admin or higher Default : 0 Effective time : Instant Note : External emergency stop button of the system This port is affected by IO configuration.
077	Arc Acc.for Radii
078	Arc Acc.for Speed
	Range : Unit : Coefficient Authority : Operation admin or higher Default : 50, 100 Effective time : Instant Note : Used to restrict the arc processing speed automatically. This parameter is valid in pretreatment mode. The bigger the radius coefficient is, the lower the arc speed is. The bigger the acceleration coefficient is, the higher the arc speed is.
079	PretreatmentCode Set
	Range : 100~1000 Unit : Instruction line Authority : Operation admin or higher Default : 500 Effective time : Instant Note : Set the pre-reading instruction lines; if the pretreatment processing pauses and pre-reads, please increase this value to pre-read more instructions.
080	Inp AccSpeed Mode
081	'S'Speed Acceleration
	Range : Unit : Authority : Operation admin or higher Default : Effective time : Instant Note : Used to set the performance of S curve acceleration/deceleration
084	HOME Check for alarm
085	HOME Check Enable
	Range : 0~1 Unit : Authority : Operation admin or higher Default : 0, 1 Effective time : Instant Note : Used to set whether prompt user to reset under certain conditions, ensuring that the user has performed the operation; If the value is set to 0, it won't check, and will run directly.
086	X diameter prog enable
	Range : 0~1 Unit : Authority : Operation admin or higher

Default : 1 (L series) /0 (M series)
 Effective time : Instant
 Note : On lathe controller (L series), it is used to set whether the display and programming of X axis are in radius or diameter;

087	default process plane
Range	: G17,18,19
Unit	:
Authority	: Operation admin or higher
Default	: G18 (L series)/G17 (M series)
Effective time	: Instant
Note	: Set the default processing plane to XY or XZ; modify the default plane, so that it isn't need to specify the modal plane value while programming, and write plane related instructions directly in stead;

088	T code form
Range	: 0~2
Unit	:
Authority	: Operation admin or higher
Default	: 2 (L series)
Effective time	: Instant
Note	: Used to set the T value in tool change instruction on lathe controller (L series); the latter digits indicate the compensation number. In some conventional programming, people usually use two digits to specify the compensation number used by corresponding tool number; For example: T0801 M06 indicates changing the #8 tool and compensating with #1 length.

089	IP address
090	subnet mask
091	default gateway
Range	:
Unit	:
Authority	: Operation admin or higher
Default	: 192.168.0.123 255.255.255.0 192.168.0.1
Effective time	: Restart
Note	: Used to configure Ethernet parameters, which shall comply with the actual network settings, or else it can't be accessed normally. After configured successfully, the user can perform the ping command test on the PC of same network segment (same subnet mask) in the intranet. The connection has error if the return overtimes. Please check the physical connection. The network environment requires independent NC network. Do not connect to office network or Internet, because the broadcast in the network and regular query of windows will block the network communication of NC.

092	Pretreatment segments
Range	: 10~200
Unit	:
Authority	: Operation admin or higher
Default	: 20
Effective time	: Instant
Note	: Pretreatment forward segments are used to set the segments of pretreatment preview. The larger this value is, the greater the operation is, and the longer the waiting time before motion is. During small segment interpolating, if this value is larger, the possibility of waiting for operation during motion will become higher; the balance value is set according to the actual processing effect. If this value is smaller, the balance value is set according to the actual price effect because the forward data are insufficient and the speed can't be improved during small segment interpolating.
093	feed speed setting En
Range	: 0~1
Unit	:
Authority	: Operation admin or higher
Default	: 0
Effective time	: Instant
Note	: This parameter is used to modify the interpolation speed in programming, making F programming invalid. Used for the cases that processing codes requires ignoring F-value.
094	enable of G00 Inp mode
Range	: 0~1
Unit	:
Authority	: Operation admin or higher
Default	: 0
Effective time	: Instant
Note	: Used to set whether G00 instruction is moved with G01 mode If G01 mode is used, the interpolation speed shall follow the setting of minimum speed; The acceleration is the interpolation acceleration.

11.3 Axis parameter configuration (P2.)

001	X_ServoAlarmIn ELevel
002	Y_ServoAlarmIn ELevel
003	Z_ServoAlarmIn ELevel
004	A_ServoAlarmIn ELevel
005	X_ServoResetOut ELevel
006	Y_ServoResetOut ELevel
007	Z_ServoResetOut ELevel
008	A_ServoResetOut ELevel

Range : 0~1
 Unit : LOGIC VOLTAGE LEVEL
 Authority : Super Admin
 Default : 0, 1
 Effective time : Instant
 Note : Adapt to the interface parameters of selected servo drive; please refer to interface voltage level description of servo for specific parameter settings.

009	X_ECZ Home Enable
010	X_ECZ Home ELevel
011	Y_ECZ Home Enable
012	Y_ECZ Home ELevel
013	Z_ECZ Home Enable
014	Z_ECZ Home ELevel
015	4_ECZ Home Enable
016	4_ECZ Home ELevel

Range : 0~1
 Unit : LOGIC VOLTAGE LEVEL
 Authority : Super Admin
 Default : 0
 Effective time : Instant
 Note : When this parameter is enabled, encoder Z phase positioning of corresponding axis will be enabled automatically in mechanical home mode, i.e. the “servo home” positioning; in this mode, the accuracy of repeated home positioning depends on servo positioning accuracy, and therefore it is recommended to enable this function for servo motor. Step motor doesn’t have encoder and can’t enable this option, or else the signals can’t be scanned during mechanical home operation and will move constantly.

017	X Limit+ Enable<●>
...	...
028	4 Limit ELevel<●>

Range : 0~1
 Unit : None
 Authority : Super Admin
 Default : 0
 Effective time : After restarted
 Note : Hard limit has two modes, i.e. hardware response and software scanning; Hardware response mode is integrated by the motion chip, and is triggered by the effective voltage level of the circuit test limit pin. Therefore, it is highly real-time, but it also has a defect. If the external interference is serious, the normal pulse will be affected and the system doesn’t alarm because it can’t read the error state in time, which will cause loss; therefore, this function requires that the wiring switch uses normally closed connection, i.e. high effective level; this function considers the complexity of field environment

and the default value is off.

Scanning mode is integrated by the system and can't be shielded. The scanning mode inputs signal by accessing specified function number, and uses software anti-interference detection technology to check whether limit alarm occurs or has no interference. This requires certain time to check, and thus the real time isn't as well as interrupted limit. However, in most cases (at 10mm/min processing speed), it can meet the requirement on processing safety check.

The hardware response function of hard limit is prior to scanning response function, i.e. if the hardware response is enabled, it will quicken the response speed directly. It should be noted that the hardware response function only can stop pulse in instant mode. Therefore, the instant stop mode may cause mechanical vibration if the speed is too high. While software scanning mode uses maximum acceleration mode and decelerates according to the maximum acceleration set to every axis by the user (parameter P2.074~077), and therefore overshoot will occur.

029	X Pulse Mode<●>
030	Y Pulse Mode<●>
031	Z Pulse Mode<●>
032	4 Pulse Mode<●>

Range : 0~1
 Unit : None
 Authority : Super Admin
 Default : 1
 Effective time : Restart
 Note : Pulse command format setting is to configure the mode of output pulse.
 The compatible command format of the motor drive should be known in advance.
 Pulse + pulse
 Pulse + direction

033	X Pulse Dir Mode<●>
034	Y Pulse Dir Mode<●>
035	Z Pulse Dir Mode<●>
036	4 Pulse Dir Mode<●>

Range : 0~1
 Unit : None
 Authority : Super Admin
 Default : 1
 Effective time : Restart
 Note : Set pulse direction; if the controller direction is reverse to actual drive direction, please modify this parameter to adjust the rotation direction of motor.

037	X Ext Home ELevel
038	Y Ext Home ELevel
039	Z Ext Home ELevel
040	A Ext Home ELevel

Range : 0~1
 Unit : LOGIC VOLTAGE LEVEL
 Authority : Super Admin
 Default : 0
 Effective time : Instant
 Note : Set the effective voltage level of external home sensor switch during home operation.
 Low level
 High level

041	X Round Setting
-----	-----------------

042	Y Round Setting
043	Z Round Setting
044	4 Round Setting

Range : 0~9999999
 Unit : Pulse
 Authority : Super Admin
 Default : 0
 Effective time : Restart
 Note : Round function is available on hardware version 1.5 or later only;
 This function is used to prevent the logic counting of axis exceeding the maximum counting range (2147483648) and causing overflow error; Generally, overflow occurs only when the axis is set to rotary. The system will calculate the corresponding pulse limit according to the gear ratio of current axis and assign to the ROUND parameter of corresponding axis, if current axis is set to rotary and uses 360° display mode after the system getting P2.062~P2.069 parameters. The user can check the change of this parameter when the rotary axis display function is enabled. The user can modify the changed parameters, and the finally displayed number will be effective.
 This parameter requires restart to take effect; the corresponding axis must be rotary and set to 360° display (P2.062~069);

045	X physial Assign Num<●>
046	Y physial Assign Num<●>
047	Z physial Assign Num<●>
048	4 physial Assign Num<●>

Range : 0~4
 Unit : Pulse port sequence No.
 Authority : Super Admin
 Default :
 Effective time : Restart
 Note : In default mode, the actual number of every axis corresponds to the silk screen number on the shell. If certain function axis is abnormal, you can replace the axis through this function. For example, set P2.045 to 4, P2.048 to 1, then, any operation to X axis will be the operation to A axis encoder port on the shell.
 0: no such axis
 1~4: corresponding to 1#-4# axis

049	spindle physial Assign Num<●>
-----	-------------------------------

Range : 0~4
 Unit : Pulse port sequence No.
 Authority : Super Admin
 Default :
 Effective time : Restart
 Note : It is set to 0 by default, indicating that the principal axis is in variable frequency control mode, i.e. analog or gear position control mode. To use servo principal axis, a coding port is required (servo principal axis must be in position control mode); you can modify this parameter to specify the function.
 0: variable frequency principal axis adjusted by analog
 1~4: corresponding to 1#-4# axis
 Note: If a pulse port is specified as the function port of principal axis, the pulse port should be removed from previously corresponding function axis number, or else the system will assign to principal axis after restarted and the original function axis will be invalid.

050	X Encoder bit(p)
051	Y Encoder bit(p)
052	Z Encoder bit(p)
053	4 Encoder bit(p)

Range : 0~9999

Unit : Wire number
 Authority : Super Admin
 Default : 2500
 Effective time : Instant
 Note : Set the encoder wires connected to every pulse port (AB phase pulse).
 Since four times frequency division is performed for internal transfer, the value of this parameter should be the pulses collected by the encoder for one cycle divided by 4.

058	X PulseLogic Level<●>
059	Y PulseLogic Level<●>
060	Z PulseLogic Level<●>
061	4 PulseLogic Level<●>

Range : 0~1
 Unit : LOGIC VOLTAGE LEVEL
 Authority : Super Admin
 Default : 0
 Effective time : Restart
 Note : Set the normal voltage level when the pulse is working. If the setting is different from the normal voltage level required by motor drive, a direction will have accumulative error during every positive and negative motion (independent of pulses). Therefore, if the positioning axis of the machine has accumulative error in a direction, please check whether this parameter matches.

062	X feature(Rotate0 Line1)
063	Y feature(Rotate0 Line1)
064	Z feature(Rotate0 Line1)
065	4 feature(Rotate0 Line1)

Range : 0~1
 Unit : None
 Authority : Super Admin
 Default : 1
 Effective time : Instant
 Note : Set axis characteristics.
 0: Rotary axis
 1: Linear axis
 The setting of this parameter and P2.066~069 axis will affect the setting of P2.041~044. Please refer to the parameter description of P2.041~044 for details.

066	X Rolling Display Usage
067	Y Rolling Display Usage
068	Z Rolling Display Usage
069	4 Rolling Display Usage

Range : 0~1
 Unit : None
 Authority : Super Admin
 Default : 0
 Effective time : Instant
 Note : Set the coordinate display mode of the axis. This parameter is valid when P2.062~P2.065 is set to 0
 0: 0~360° display
 1: -9999.999~9999.999° display
 The setting of this parameter and P2.062~065 axis will affect the setting of P2.041~044. Please refer to the parameter description of P2.041~044 for details.

070	X Rolling Path Optimize
...	...
073	4 Rolling Path Optimize

Range : 0~1
 Unit : None
 Authority : Super Admin
 Default : 1
 Effective time : Instant
 Note : This parameter is valid when P2.062~P2.065 and P2.066~P2.069 are set to 0; set whether looking for shortest path automatically; if it is rotary axis and is positioning but doesn't process, enable this function to shorten the motion time.
 0: Do not optimize the path
 1: Enable the shortest path
 Note: If processing is required during the motion, the shortest path may be not your desired processing track.

074	Max Acc of X(Kpps)
...	...
077	Max Acc of 4(Kpps)

Range : 100~8000
 Unit : Kpps (Kilo Pulse Per Second)
 Authority : Super Admin
 Default : 2000
 Effective time : Instant

Note : Set the maximum acceleration of every axis. This setting will affect the track speed optimization of pretreatment to every axis. If a high value is set, the axis response time will be shortened and characteristics of the motor will be improved according to the machine tool.
 This parameter also affects the home function and limit stop function.
 Hard limit function: Use hard limit in software scanning mode, in which the hard limit decelerates and stops according to the maximum acceleration of this axis. Therefore, if this value is too high, the machine tool will stop in emergency, and if this value is too low, it will cause too much overshoot.
 Home function: the home acceleration of every axis uses this value.

078	X Servo Home Dir
079	Y Servo Home Dir
080	Z Servo Home Dir
081	4 Servo Home Dir

Range : 0~1
 Unit : None
 Authority : Super Admin
 Default : 0
 Effective time : Instant
 Note : This parameter determines the Z phase search direction when servo Z phase enable parameter is enabled in P2.009~P2.016.
 0: Positive
 1: Negative

082	X Ext Home Eanble
083	Y Ext Home Eanble
084	Z Ext Home Eanble
085	4 Ext Home Eanble

Range : 0~1
 Unit : None
 Authority : Super Admin
 Default : 1
 Effective time : Instant
 Note : When mechanical home mode is selected, this parameter determines whether external deceleration switch should be searched. If this parameter is set to 0, and P2.009~P2.016 (servo Z phase enable) is also set to 0, the home mode sets current point as the home directly in mechanical mode.
 0: No
 1: Yes

086	X Encoder LogicDir<●>
087	Y Encoder LogicDir<●>
088	Z Encoder LogicDir<●>
089	4 Encoder LogicDir<●>

Range : 0~1
 Unit : None
 Authority : Super Admin
 Default : 0
 Effective time : Instant
 Note : If the logic direction obtained by the encoder is reverse to the actual motion direction of the axis, please set this parameter.
 Handwheel encoder reuses A axis encoder.
 Principal axis encoder reuses X axis encoder.
 0: Positive
 1: Negative

090	X HomeSpeed2
091	Y HomeSpeed2
092	Z HomeSpeed2
093	4 HomeSpeed2
094	X HomeSpeed3
095	Y HomeSpeed3
096	Z HomeSpeed3
097	4 HomeSpeed3

Range : 1~20000
 Unit : mm/min
 Authority : Super Admin
 Default : 100, 60
 Effective time : Instant
 Note : Used to set the speed parameters of mechanical resetting; the specific effective sequence follows:
 Resetting speed ——> (when detecting external zero switch) deceleration ——> scanning speed

100	hand wheel encoder dir
-----	------------------------

Range : 0~1
 Unit : None
 Authority : Super Admin
 Default : 0
 Effective time : Instant
 Note : When the logic direction obtained by handheld box encoder is reverse to the actual motion direction of the axis, set this parameter to perform in-phase setting.
 0: positive direction
 1: negative direction

101	X restrain acc (mm/s^2)
102	Y restrain acc (mm/s^2)
103	Z restrain acc (mm/s^2)
104	4 restrain acc (mm/s^2)
105	X max restrain rate
106	Y max restrain rate
107	Z max restrain rate
108	4 max restrain rate

Range	:	1~90000
Unit	:	
Authority	:	Super Admin
Default	:	90000
Effective time	:	Instant
Note	:	Used to configure the restriction acceleration of every axis during pretreatment processing. No matter which parameter, the lower the setting is, the slower the processing speed is; vice versa. The setting value should be as high as possible if each axis permits. In comprehensive parameter P1.58 (interpolation speed mode), this parameter is valid if it is set to 1; the default setting is invalid.

11.4 Management parameters (P3.)

001	Select SupMode
002	AlterSuperuserPasswor
003	Alter User Password
	<p>Range : None</p> <p>Unit : None</p> <p>Authority : None</p> <p>Default : None</p> <p>Effective time : Instant</p> <p>Note : In this menu, type the password and press 'Insert'. If the password is valid, the system will enter this user mode; After entering, this menu will turn into "Exit XXX admin mode", indicating entering successfully; In the new menu, press the Insert key to exit the admin mode. To modify the parameter table at this moment, you need to enter the admin mode again; The super user can modify all passwords, while the operation user only can modify the own password. Password 0 indicates that the password isn't checked in this mode; it isn't required to enter the admin mode to modify the parameters.</p>
004	Initialize
005	Initialize IO Config
006	all para reset<●>
	<p>Range : None</p> <p>Unit : None</p> <p>Authority : Super user</p> <p>Default : None</p> <p>Effective time : Instant</p> <p>Note : Initial parameter table only in super user mode</p>

007	para backup
008	para recover
	Range : None Unit : None Authority : Super user Default : None Effective time : Instant Note : The parameters are backed up and restored only in super user mode. The parameters are backed up to the sysconf.bak file in the root directory of the controller. If this folder already has a file with same name, the latest backup will overwrite this file. The sysconf.bak file in the root directory is also used for restoring. During restoring, it will check whether the parameter versions are same according to the backed up parameter version; if not, the system won't restore the parameter table. After restoring, the system will restart automatically.
009	generate cryptogram
	Range : None Unit : None Authority : None Default : None Effective time : Instant Note : If you have forgotten the password, you can generate a PassMeg.DAT file with this function, provide this file to controller manufacturer and ask the manufacturer to reset the password.
010	menu click way
	Range : 0~1 Unit : None Authority : None Default : 0 (click) Effective time : Instant Note : This function is to be developed
011	clear add up work num
012	clear current work num
	Range : None Unit : None Authority : None Default : None Effective time : Instant Note : Clear the accumulated value of current processing pieces
013	lead in CSV sys config
	Range : None Unit : None Authority : None Default : None Effective time : Restart Note : Import the CSV system configuration of the manufacturer into the system
014	startup display module
	Range : Select Unit : None Authority : Operation admin Default : ABS Effective time : Instant Note : Select default boot screen from absolute position, relative position and comprehensive position.

015	sys language bag
	Range : 0~1 Unit : None Authority : Operation admin Default : 0 (Chinese) Effective time : Instant Note : Select system language Chinese English
016	macro key word valid En
	Range : 0~1 Unit : None Authority : Operation admin Default : 0 (Chinese) Effective time : Instant Note : Macro keyword effective parameter is used to set whether the macro expression symbol on the membrane is valid (1: valid, 0: invalid).
017	startup picture display
	Range : 0~6 Unit : None Authority : Operation admin Default : 1S Effective time : Instant Note : Used to configure the display mode of the logo; if it is set to 0, the user needs to press any key to enter the system; for any other value, the system delays for corresponding time and enters automatically.
018	sys display axis setting
	Range : Unit : None Authority : Super user Default : XYZ Effective time : Instant Note : Used to configure the display axis of current system, and different display combinations are available. This configuration only determines the content of the interface. If the axis function of the hardware exists, it still can output axis control during programming, but the axis status won't be displayed. The status such as axis limit and alarm will be ignored.
019	sys debug information En
	Range : 0~1 Unit : None Authority : Super user Default : OFF/0 Effective time : Instant Note : Used to configure whether RS232 of current system outputs the testing info while program is running. This parameter is dedicated for programmers, and the users are not suggested using this parameter. If the testing info is enabled, the system performance will be lowered, and therefore it is disabled during normal processing. If networking is enabled, this function must be disabled, or else the networking will fail.

020	axis control composite
Range	: 0~1
Unit	: None
Authority	: Super user
Default	: ON/1
Effective time	: Instant
Note	: Used to configure whether the key for axis motion on the control panel is enabled. This parameter is used to shield the composite function of the key for axis motion on the NC panel and reduce the possibility of misoperation when additional panel is used. However, if no additional panel is used, this parameter must be enabled, or else the axis motion can't be controlled through the key.
021	additional panel enable
Range	: 0~1
Unit	: None
Authority	: Super user
Default	: OFF/0
Effective time	: Instant
Note	: Used to configure whether NC uses additional panel, which must be ADT matching additional panel, or compatible with the interface of same protocol. If additional panel is used, the system testing info enable must be deactivated (P3.19).
022	sys tool outlay enable
Range	: 0~1
Unit	: None
Authority	: Super user
Default	: OFF/0
Effective time	: Instant
Note	: Used to configure the ATC function of the system, which is achieved by calling out T_FUNC.NC or not.

11.5 Tool magazine parameters (P4.)

001	Customized by manufacturer
Range	:
Unit	:
Authority	: Operation admin or higher
Default	:
Effective time	: Instant
Note	: This parameter is determined by tool magazine design of each machine tool manufacturer. Please refer to the machine too manuals for details.

11.6 Principal axis parameters (P5.)

001	Spi.Alarm ELevel
002	Spi.Reset ELevel
003	Spi.ECZ Home Enable
004	Spi.ECZ Elevel
005	Spi. Limit+ Enable
006	Spi. Limit- Enable
007	Spi.Limit Elevel
008	Spi.Pulse Mode
009	Spi.Pulse Logic Mode
010	Spi.HomeDect ELevel
011	Spi.ExtHome Check En
012	Spi.Round Setting
014	Spi.ZeroOffset(p)
015	Spi.PulseLogic Level
016	Spi.Rolling Display Usage
017	Spi.Max Acc(Kpps)
018	Spi.Ext HomeDir
019	Spi.Servo HomeDir
021	Spi.Home Speed(rpm)

Range :
 Unit :
 Authority : Operation admin or higher
 Default :
 Effective time :
 Note : Servo principal axis parameters are same as common positioning axis parameters. If only the principal axis is controlled with servo port, you can set the number according to axis parameters.

013	Spi.Encode bits(p)
-----	--------------------

Range : 64~9999
 Unit : None
 Authority : Operation admin or higher
 Default : 2500
 Effective time : Instant
 Note : The received wire number of the encoder when the principal axis rotates one circle;
 Same as common axis encoder, it can only receive AB phase pulse, and thus the wire number of the encoder must be pulses of one circle divided by 4.
 This parameter will affect G74 and G84 tap instructions. Please set it properly.

020	Spi.Max Speed(rpm)
-----	--------------------

Range : 1~30000
 Unit : None
 Authority : Operation admin or higher
 Default : 24000
 Effective time : Instant
 Note : This setting is used to calculate the analog output of the controller, and suppose that the analog of variable frequency control is in linear control mode;
 This method is to set the rotation to this parameter according to the variable frequency rotation corresponding to analog 10V, and transfer the

rotation directly later, while the controller will output corresponding analog voltage according to linear scale automatically.

022	Spi.Gear Numerator
023	Spi.Gear Denominator
	Range : 1~65535
	Unit : None
	Authority : Operation admin or higher
	Default : 1
	Effective time : Instant
	Note : If the principal axis has gear position, please set the hardware gear ratio to this parameter, which hasn't been used in standard version, but may be used in certain special conditions.

11.7 Port configuration (P6.)

001	Wheel0.1----- Input wire No.
...	...
014	4 Alarm----- Input wire No.
	Range : 0~24
	Unit : None
	Authority : Super Admin
	Default : The port table in the manual
	Effective time : Instant
	Note : Handheld box interface and servo alarm function pin definition; Type 8888 and press Insert, the system won't map and will use the default wire No. in the manual. If the operation is successful, it displays "-----"; Input value 1~24: map to corresponding pin on IO board

015	IN0----- Input wire No.
...	...
038	IN23----- Input wire No.
	Range : 1~24
	Unit : None
	Authority : Super Admin
	Default : The port table in the manual
	Effective time : Instant
	Note : Input terminal No. configuration parameter Terminal No. is the object of the system to control IO, e.g. X external home signal test, the system tests terminal No. IN0, which corresponds to input wire 1 by default, and thus the system tests input pin1 indirectly; by default, the terminal No. is assigned to wire No. according to the IO relationship in the manual; however, this relationship isn't constant, and you can specify in these parameters and reassign a terminal No. to any input port; For example, if you set 10 in parameter 042, the system will test pin 10 instead of pin 1 when it tests X home signal during home operation.

039	OUT0----- Output wire No.
...	...
062	OUT23----- Input wire No.
	Range : 1~24
	Unit : None
	Authority : Super Admin
	Default : The port table in the manual
	Effective time : Instant

Note : Output terminal No. configuration is same as input terminal configuration. Output terminal No. and wire No. are mapped

063	Safe Signal
...	...
087	TCheck Limit DetectPort

Range : 0~23
 Unit : Terminal No.
 Authority : Super Admin
 Default : The port table in the manual
 Effective time : Instant
 Note : System functions correspond to assigned terminal No.;
 Terminal No. is also set by parameter 15~62, and mapped to specified wire No.;
 To shield this function, you can type 8888 and press Insert. This operation is in background, and displays “255” if the operation is successful.

083	IO Conf in RESET 00~15
084	IO Conf in RESET 16~23

Range : 0~65535
 Unit :
 Authority : Super Admin
 Default : 65404
 Effective time : Instant
 Note : Used to configure the IO signal that the system needs to reset when there is alarm.
 Use binary system to configure in positions.
 For example: 83:65404, is 1111 1111 0111 1100 in binary system;
 Which indicates that port 0, 1 and 7 won't be reset due to system pause or alarm.

12. Hardware interface definition and connection instructions

12.1 Installation layout

12.1.1 External interface diagram

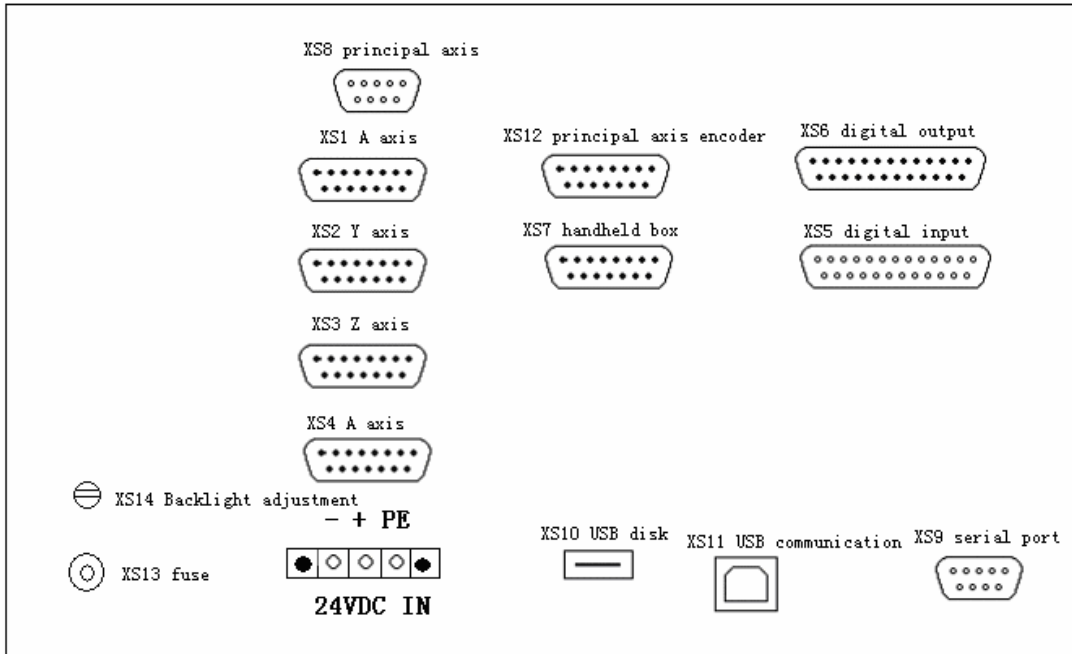

(1) X axis, Y axis, Z axis, A axis:

15-core D-pin socket connects to step motor drive or digital AC servo drive

(2) XS5 digital input:

25-core D-pin socket inputs signals for every axis limit and other switching quantity

(3) XS6 digital output:

25-core D-pin socket outputs signals for switching quantity

(4) USB and serial port exchange files between PC and CNC4640 controller and realize other functions.

(5) CNC4640 controller uses 24V DC power supply, and the internal power consumption is about 5W.

(6) XS7 accessory panel:

15-core D-pin socket connects to handwheel

(7) XS8 principal axis:

9-core D-pin socket connects to principal axis inverter

12.1.2 Mounting dimensions

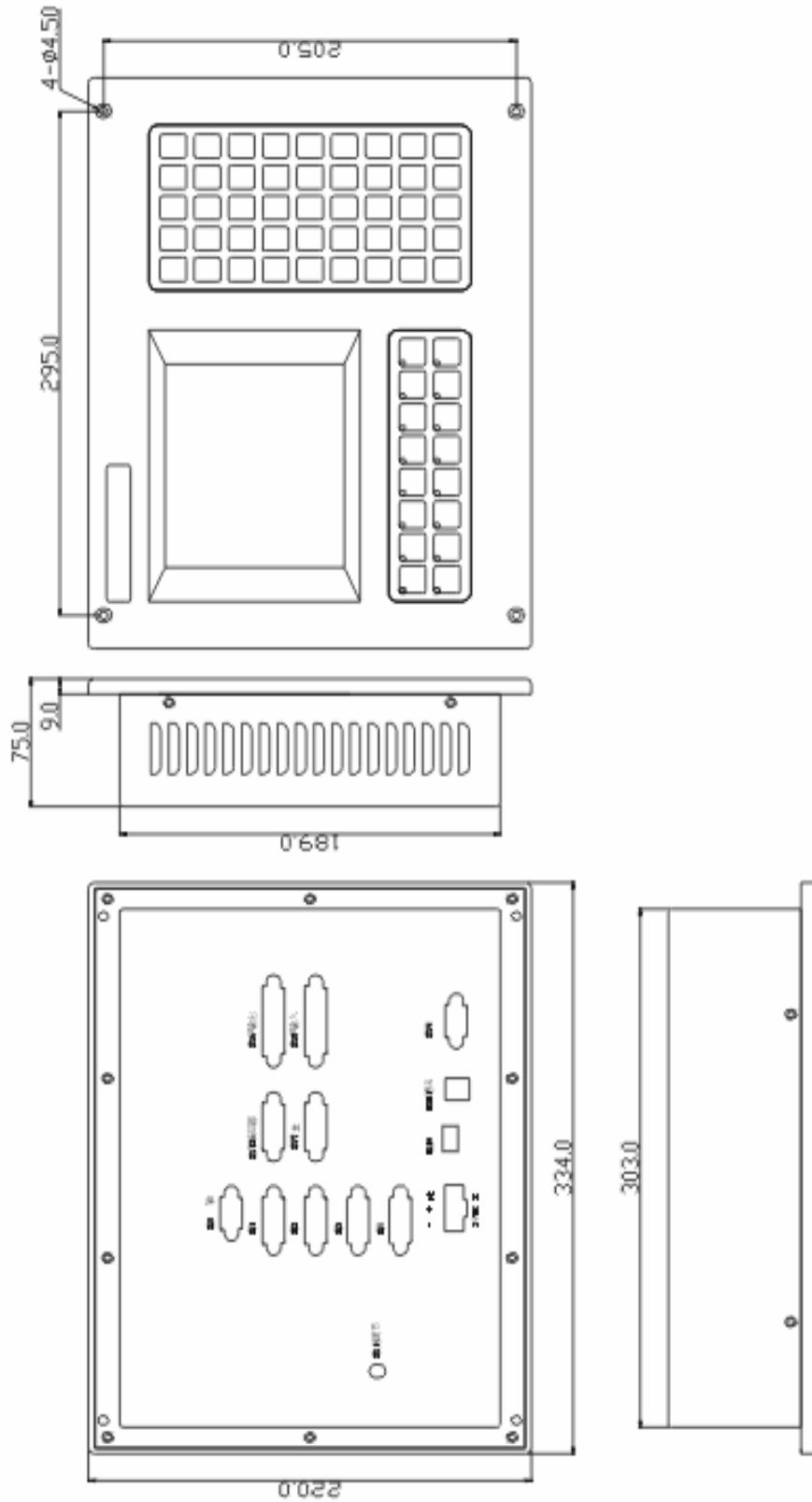

12.1.3 Installation precautions

Installation condition for electric cabinet

(1) The cabinet must be able to effectively prevent dust, coolant and organic solution entering;

(2) When design electric cabinet, the distance between rear cover and case should be at least 20CM; considering the temperature rises in the cabinet, the temperature difference between interior and exterior of the cabinet shouldn't exceed 10°C;

(3) The cabinet should be installed with fan to ensure interior ventilation;

(4) The display panel should be installed at the position can't be sprayed by the coolant;

(5) When design electric cabinet, the external electrical interference should be reduced to lowest to prevent interfering with the system;

To prevent interference

The system is designed with anti-interference measures such as shielding space electromagnetic radiation, absorbing impact current and filtering power clutter, which can prevent interference with the system in certain degree. To ensure system stability, please take the following measures to install and connect the system:

(1) CNC must be kept away from the equipment with interference (e.g. inverter, AC contactor, electrostatic generator, high voltage generator, and sub-unit of power lines), and the switching power supply should be connected to a filter to improve the anti-interference of CNC (as in Fig.1-4);

(2) To supply power to the system through isolation transformer, the machine tool must be grounded, CNC and drive must be connected to separate earth wire.

To suppress interference

Connect RC circuit ($0.01\mu\text{F}$, $100\sim 200\Omega$, as in Fig. 1-5) to both sides of AC coil in parallel. RC circuit should be installed close to inductive load; connect freewheeling diode reversely on both sides of DC coil in parallel (as in Fig.1-6); connect surge absorber to the winding of AC motor in parallel (as in Fig. 1-7).

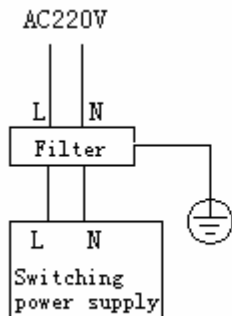

Fig. 1-4

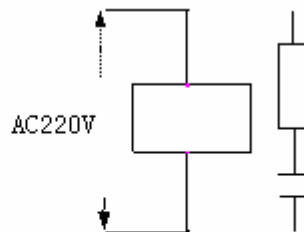

Fig. 1-5

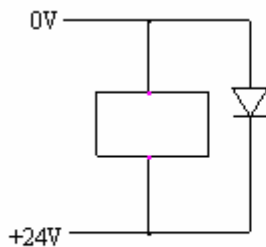

Fig. 1-6

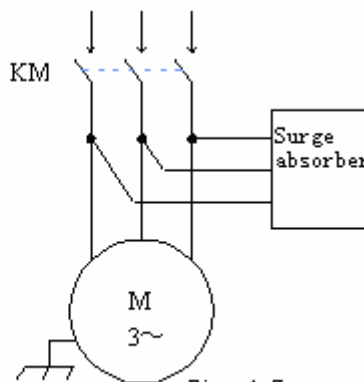

Fig. 1-7

To reduce the interference between CNC signal cables and strong current cables, the wiring shall follow the principles below:

Group	Cable type	Wiring Requirement
A	AC power cord	Bundle the cables of group A separately from group B and C, keep at least 10cm clearance, or make electromagnetic shielding for group A
	AC coil	
	AC contactor	
B	AC coil (24VDC)	Bundle the cables of group B separately from group A or shield group B; group B and group C should be as far as possible
	DC relay (24VDC)	
	Cable between system and strong current cabinet	
	Cable between system and machine tool	
C	Cable between system and servo drive	Bundle the cables of group C separately from group A, or shield group C; keep at least 10cm clearance between group C and group B and use twisted pair
	Position feedback cable	
	Position encoder cable	
	Handwheel cable	
	Other cables for shielding	

12.2 Interface definition

12.2.1 Motor drive control interface (XS1..XS4)

Four drive interfaces are available (XS1 X axis, XS2 Y axis, XS3 Z axis, XS4 A axis), and they have the same definition, as shown below:

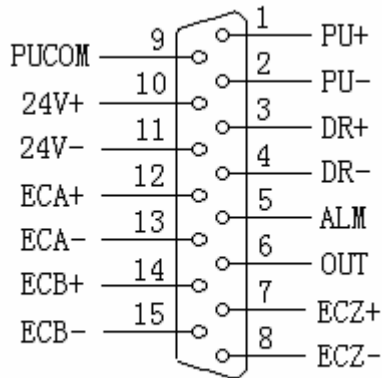

CNC4620/4640 pulse connection

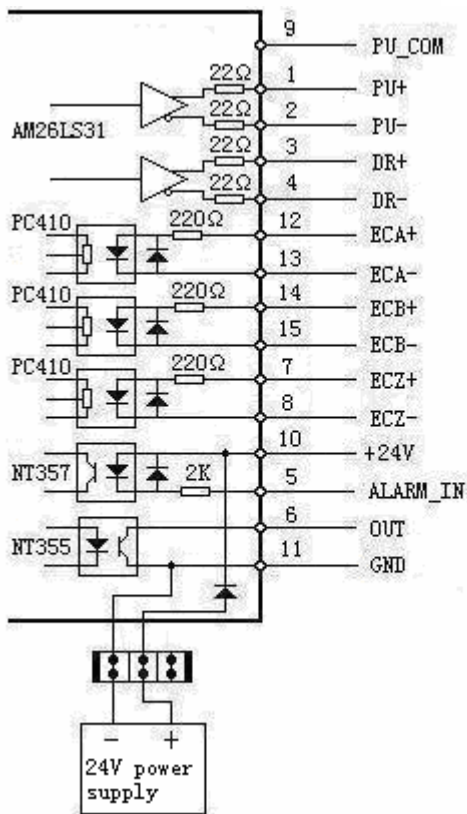

Simple Internal Circuit Diagram for Pulse Output

Wire No.	Definition	Function
1	PU+	Pulse signal +
2	PU-	Pulse signal -
3	DR+	Direction signal +
4	DR-	Direction signal -
5	ALM	Servo alarm signal input X axis: IN34, Y axis: IN35, Z axis: IN36, A axis: IN37
6	OUT	Axis alarm reset output signal X axis: OUT24, Y axis: OUT25, Z axis: OUT26 A, axis: OUT27
7	ECZ+	Encoder phase Z input +
8	ECZ-	Encoder phase Z input -
9	PUCOM	Controller for single end input
10	24V+	Internally provided 24V power supply, directly connected to 24V power supply of the controller
11	24V-	
12	ECA+	Encoder phase A input +
13	ECA-	Encoder phase A input -
14	ECB+	Encoder phase B input +
15	ECB-	Encoder phase B input -

Standard pulse wiring diagram

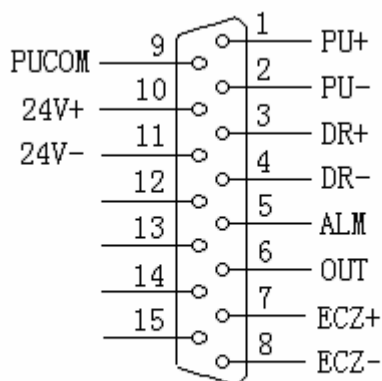

XS1 ... XS4 Pulse Interfaces Standard Wiring

This wiring is suitable for CNC4640/4620/4340/4240/4342 controller;

Step motor drive cable to differential input

Adtech CNC drive is for reference, all of which use differential input mode. This mode has strong anti-interference and is recommended. Please refer to the figure below for the connection of CNC with step motor drive and step motor

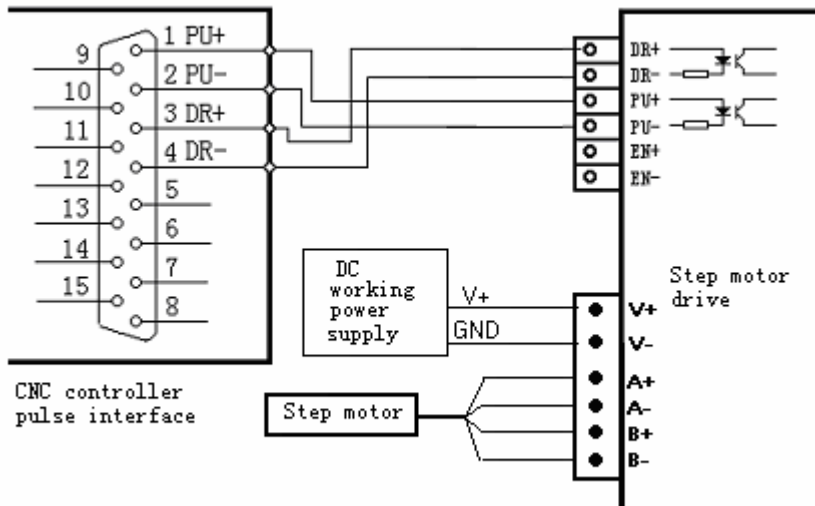

Step motor drive wiring diagram for single-ended input

Certain companies connect together the optocoupler input cathodes of step drives, i.e. common cathode connection, which isn't suitable for CNC controller. Common anode connection connects together the anodes of optocoupler input. The wiring shall follow the figure below, and do not connect PU+ and DR+ together, or else the pulse interface may be damaged.

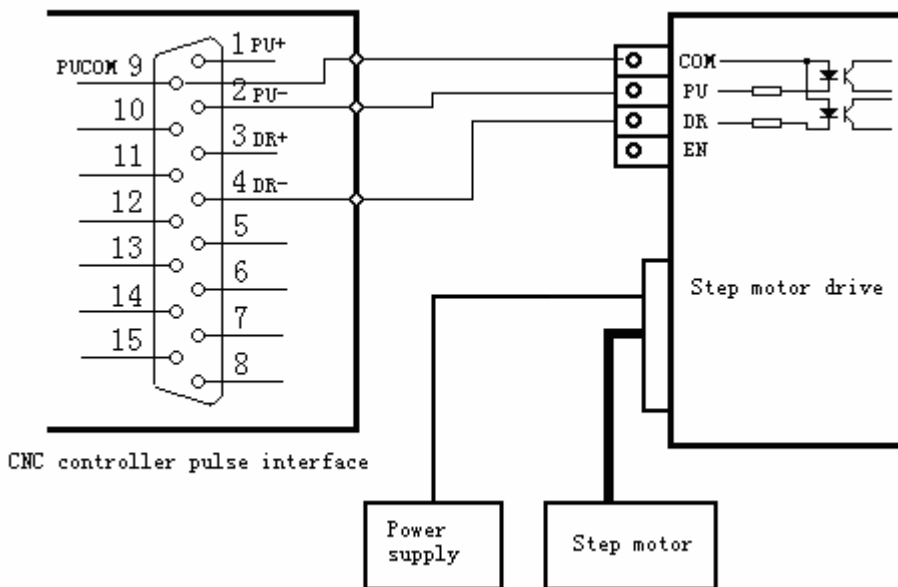

Wiring Diagram for Step Motor Drive with Common Anode Input

Servo motor drive wiring diagram

Since differential connection is used in most cases, please refer to differential mode for the pulse connection. Most servo drives require 12-24V power supply, and the 24V power provided by pin 10, 11 is available. The specific connection depends on servo drive. Please contact us if you have any question.

⚡ Caution

Either two of PU+, PU-, DR+ and DR- shouldn't be connected, or else the pulse interface may be damaged.

12.2.2 Digital input interface (XS5)

The digital input interface contains the hard limit signal of every axis, and the definition follows:

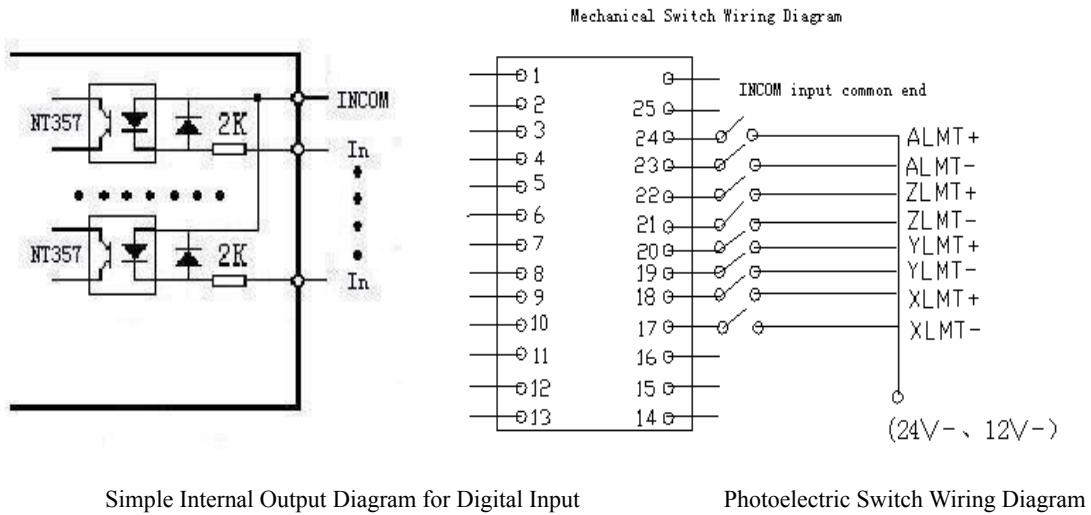

Simple Internal Output Diagram for Digital Input

Photoelectric Switch Wiring Diagram

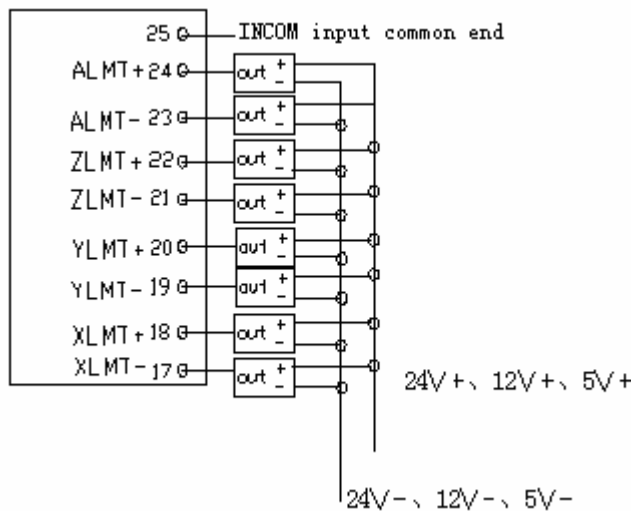

+ is the anode of approach switch, - is the earth wire, and OUT is output signal. For common approach switch, please select 10-30V power supply and NPN output. Photoelectric switch is similar.

Default input port configuration of M series (milling machine)

Wire No.	Definition	Function
1	IN0	X axis zero point
2	IN1	Y axis zero point
3	IN2	Z axis zero point
4	IN3	A axis zero point
5	IN4	Tool regulator in place test
6	IN5	Security door test input
7	IN6	System under-voltage alarm input
8	IN7	System lubricant pressure alarm input
9	IN8	Standby input
10	IN9	Standby input
11	IN10	System material clamping alarm input
12	IN11	Standby input
13	IN12	Standby input
14	IN13	Standby input
15	IN14	Standby input
16	IN15	Standby input
17	IN16 (XLMT-)	X axis negative limit (standby IN32)
18	IN17 (XLMT+)	X axis positive limit (standby IN33)
19	IN18 (YLMT-)	Y axis negative limit (standby IN34)
20	IN19 (YLMT+)	Y axis positive limit (standby IN35)
21	IN20 (ZLMT-)	Z axis negative limit (standby IN36)
22	IN21 (ZLMT+)	Z axis positive limit (standby IN37)
23	IN22 (ALMT-)	A axis negative limit (standby IN38)
24	IN23 (ALMT+)	A axis positive limit (standby IN39)
25	INCOM	Input common end INCOM (24V+, 12V+) connects to internal or external power supply

Default input port configuration of L series (lathe)

Wire No.	Definition	Function
1	IN0	X axis zero point
2	IN1	Standby input
3	IN2	Z axis zero point
4	IN3	Standby input
5	IN4	Tool #1 in place test
6	IN5	Tool #2 in place test
7	IN6	Tool #3 in place test
8	IN7	Tool #4 in place test
9	IN8	Tool #5 in place test
10	IN9	Tool #6 in place test
11	IN10	Tool #7 in place test
12	IN11	Tool #8 in place test
13	IN12	Standby input
14	IN13	Standby input
15	IN14	Standby input
16	IN15	Standby input
17	IN16 (XLMT-)	X axis negative limit (standby IN32)
18	IN17 (XLMT+)	X axis positive limit (standby IN33)
19	IN18	
20	IN19	
21	IN20 (ZLMT-)	Z axis negative limit (standby IN36)
22	IN21 (ZLMT+)	Z axis positive limit (standby IN37)
23	IN22	
24	IN23	
25	INCOM	Input common end INCOM (24V+, 12V+) connects to internal or external power supply

12.2.3 Digital output interface (XS6)

The wiring of digital output interface follows:

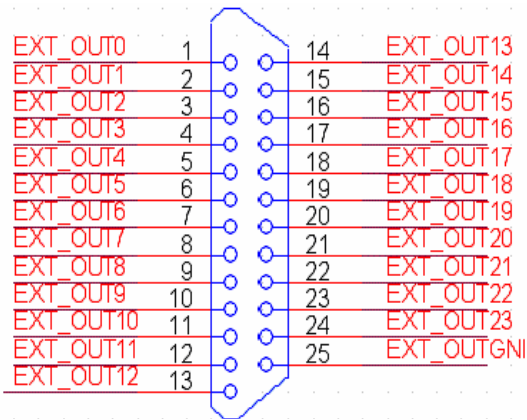

XS6 Output Interface Wiring Diagram

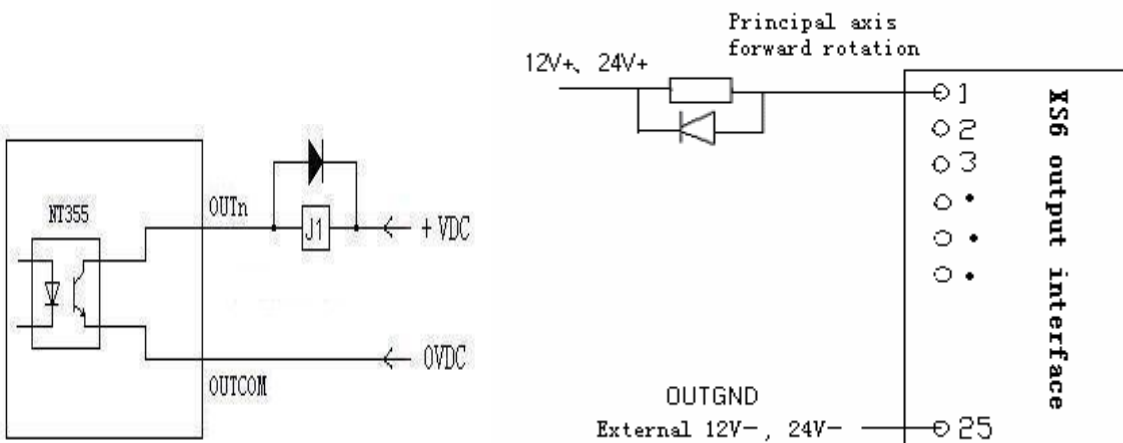
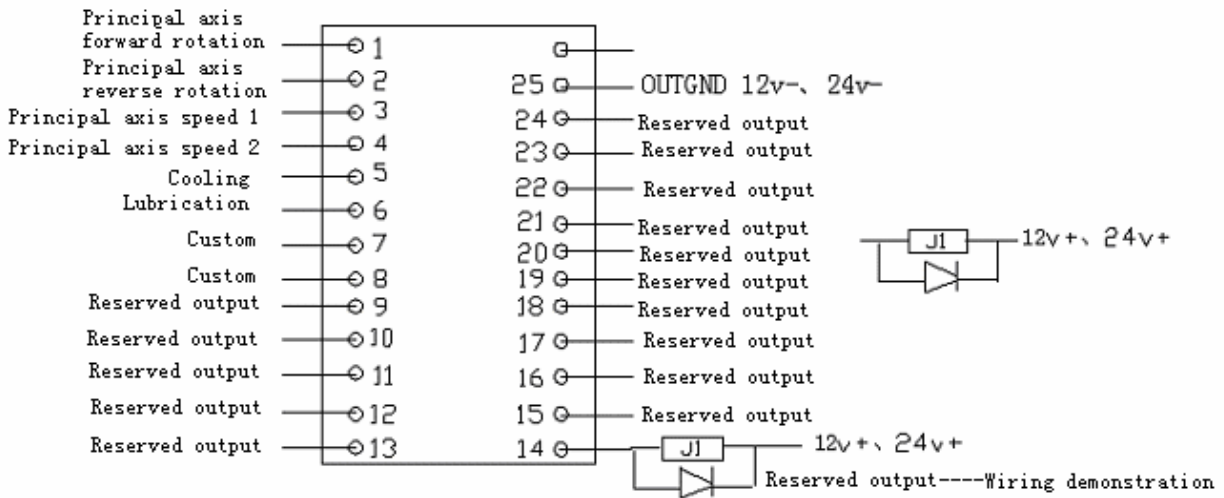

Simple Internal Circuit of Digital Output (left)

Wiring with Machine Tool (right) (principal axis positive rotation for example)

Default output port configuration of M series (milling machine)

Wire No.	Definition	Function
1	OUT0	Principal axis positive rotation (M03)
2	OUT1	Principal axis reverse rotation (M04)
3	OUT2	Standby output (M56, M57)
4	OUT3	Standby output (M58, M59)
5	OUT4	Cooling (M08, M09)
6	OUT5	Lubricating (M32, M33)
7	OUT6	Standby output (M10, M11)
8	OUT7	Timing oil pump output of the system
9	OUT8	Standby output (M12, M13)
10	OUT9	Standby output (M14, M15)
11	OUT10	Standby output (M16, M17)
12	OUT11	Standby output (M18, M19)
13	OUT12	Standby output (M40, M41)
14	OUT13	Standby output (M42, M43)
15	OUT14	Standby output (M44, M45)
16	OUT15	Standby output (M46, M47)
17	OUT16	Standby output (M48, M49)
18	OUT17	Standby output (M50, M51)
19	OUT18	Alarm indicator
20	OUT19	Running indicator
21	OUT20	Variable frequency speed switch 3 (M66, M67)
22	OUT21	Variable frequency speed switch 2 (M64, M65)
23	OUT22	Variable frequency speed switch 1 (M62, M63)
24	OUT23	Variable frequency speed switch 0 (M60, M61)
25		OUTGND12V-, 24V- common power supply of external output

Default output port configuration of L series (lathe)

Wire No.	Definition	Function
1	OUT0	Principal axis positive rotation (M03)
2	OUT1	Principal axis reverse rotation (M04)
3	OUT2	Tool regulator positive rotation output (M56, M57)
4	OUT3	Tool regulator reverse rotation & locking output (M58, M59)
5	OUT4	Cooling (M08, M09)
6	OUT5	Lubricating (M32, M33)
7	OUT6	Standby output (M10, M11)
8	OUT7	Standby output (M20, M21)
9	OUT8	Chuck locking (M12)
10	OUT9	Chuck loosening (M13)
11	OUT10	Standby output (M16, M17)
12	OUT11	Standby output (M18, M19)
13	OUT12	Standby output (M40, M41)
14	OUT13	Standby output (M42, M43)
15	OUT14	Standby output (M44, M45)
16	OUT15	Standby output (M46, M47)
17	OUT16	Standby output (M48, M49)
18	OUT17	Standby output (M50, M51)
19	OUT18	Standby output
20	OUT19	Standby output
21	OUT20	Variable frequency speed switch 3 (M66, M67)
22	OUT21	Variable frequency speed switch 2 (M64, M65)
23	OUT22	Variable frequency speed switch 1 (M62, M63)
24	OUT23	Variable frequency speed switch 0 (M60, M61)
25		OUTGND12V-, 24V- common power supply of external output

12.2.4 Handheld box interface (XS7)

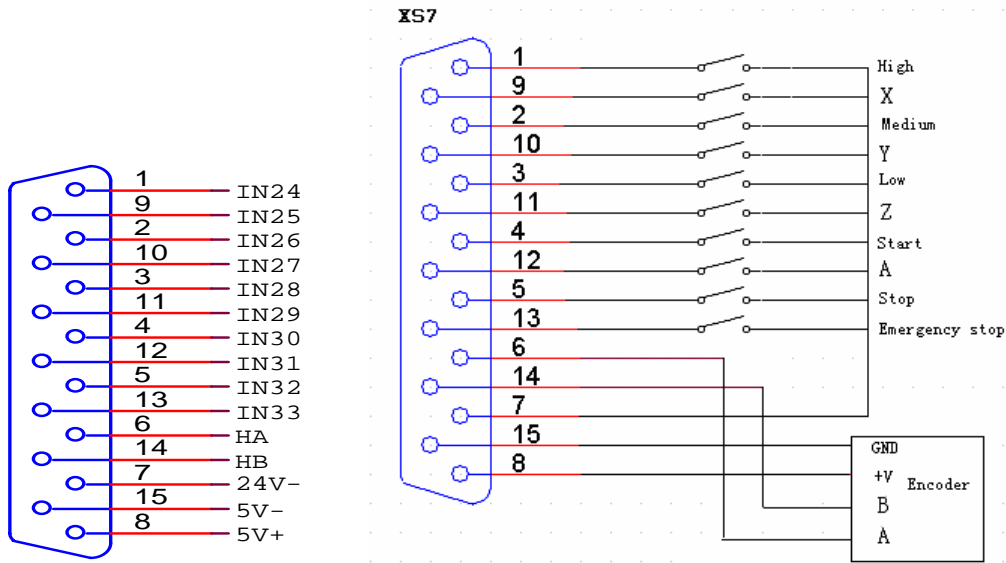

Wire No.	Definition	Function
1	(IN24) gear switch	0.1 gear --- High speed
2	(IN26) gear switch	0.01 gear --- Medium speed
3	(IN28) gear switch	0.001 gear --- Low speed
4	(IN30) button	Cycle start
5	(IN32) button	Emergency stop
7	24V-	Negative pole of internally provided 24V power supply
9	(IN25) axis selection	X axis
10	(IN27) axis selection	Y axis
11	(IN29) axis selection	Z axis
12	(IN31) axis selection	A axis
13	(IN33) button	Emergency stop
6	HA	Hand encoder phase A input signal
14	HB	Hand encoder phase B input signal
15	5V-	Negative pole of internally provided 5V power supply
8	+5V	Positive pole of internally provided 5V power supply
7	24V-	Negative pole of internally provided 24V power supply

12.2.5 Analog output interface (XS8)

Analog output interface wiring diagram:

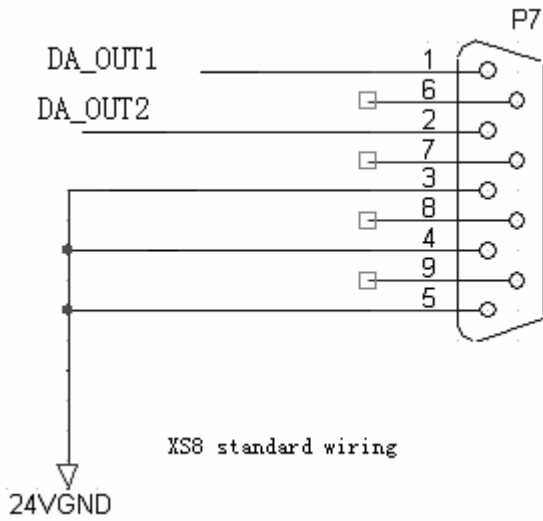

The wiring is also suitable for XS8 interface of 4640/4620 controller;

Wiring diagram of analog principal axis XS8 and inverter

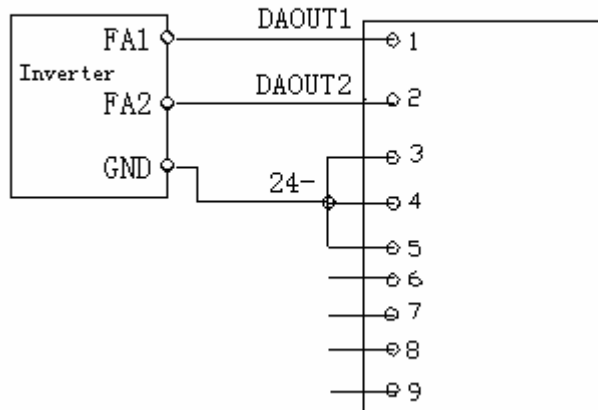

Wire No.	Definition	Function
1	DAOUT1	Analog voltage output (0~10) V
2	DAOUT2	Analog voltage output (0~10) V
3	GND	Internal 24V power grounding
4	GND	Internal 24V power grounding
5	GND	Internal 24V power grounding

12.2.6 Principal axis encoder interface (XS12)

Principal axis encoder wiring diagram:

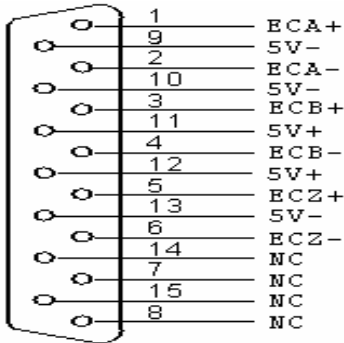

This wiring is suitable for 4640/4620 controller

Wire No.	Definition	Function
1	ECA+	Encoder phase A input +
2	ECA-	Encoder phase A input -
3	ECB+	Encoder phase B input +
4	ECB-	Encoder phase B input -
5	ECZ+	Encoder phase Z input + (standby)
6	ECZ-	Encoder phase Z input - (standby)
7	NC	Null
8	NC	Null
9	5V-	Negative end of internal 5V power supply; can't be connected to external power supply
10	5V-	Negative end of internal 5V power supply; can't be connected to external power supply
11	5V+	Positive end of internal 5V power supply; can't be connected to external power supply
12	5V+	Positive end of internal 5V power supply; can't be connected to external power supply
13	5V-	Negative end of internal 5V power supply; can't be connected to external power supply
14	NC	Null
15	NC	Null

- AB phase decoder input allows differential connection and common anode connection, which will be determined by the encoder type.
- Encoder output modes include open collector, complementary, voltage and long drive, among which open collector, complementary and voltage output use common anode connection, and long drive output uses differential connection.
- As shown in the figure below, AB phase decoder input signal uses differential input connection; if common anode connection is used, the positive ends of phase A and phase B must be connected; for common cathode connection, the negative ends of phase A and phase B must be connected.

Differential connection follows:

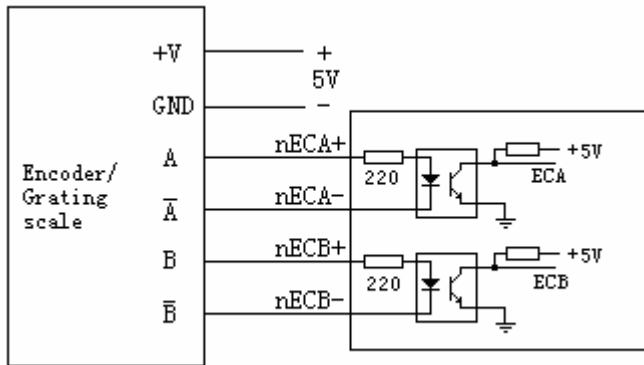

- 5V power supply is external

Common anode connection follows:

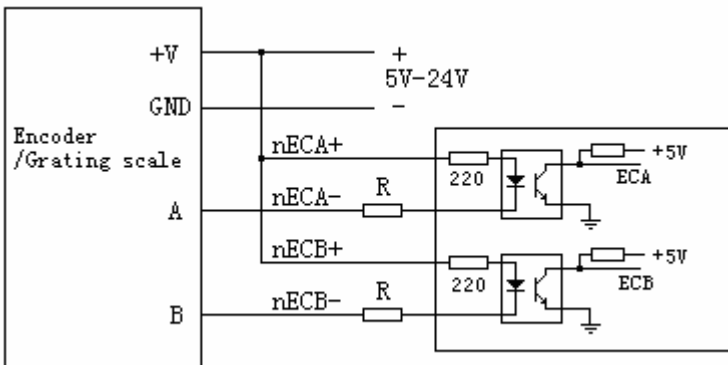

- The power voltage is determined by encoder. If 5V power supply is used, resistor R will be unnecessary. For 12V power supply, please use 1K-2K resistor, and for 24V power supply, please use 2K-5K resistor.

Suggestion:

Please use differential output encoder to ensure better anti-interference when the line is long.

12.2.7 RS232 transmission interface (XS9)

Serial communication interface ---9-core signal socket (male)

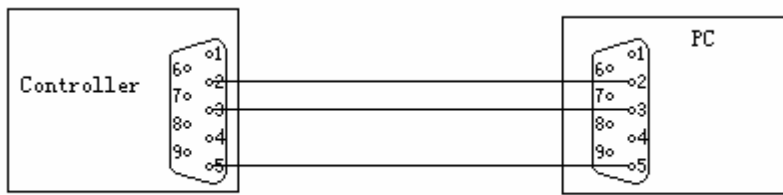
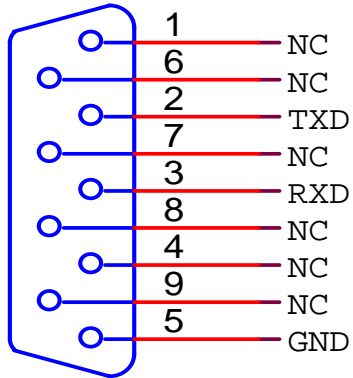

RS-232 communication mode

12.2.8 USB memory connection interface (XS10)

Standard USB memory (e.g. USB disk) interface;

12.2.9 PC USB communication interface (XS11)

Standard USB communication interface;

12.3 Electrical connection diagram

12.3.1 Symbol schematic diagram

Symbol	Name	Figure	Symbol	Name	Figure
QF	Breaker		SM	Servo motor	
KM	Contactactor		M	Step motor	
UF	Inverter		SQ	Approach switch	
M	Motor		SA	Foot switch	
TC	Transformer		YB	Motor brake	
Z	Filter		FR	Thermal relay	
FU	Fuse		UC	Switching power supply	
SB	Button		YV	Electromagnetic valve	
FM	Fan		C	Capacitor	
HL	Indicator		R	Resistor	
QS	Touch switch		QS	Travel switch	
PG	Encoder		KA	Relay	

12.3.2 Power connection diagram

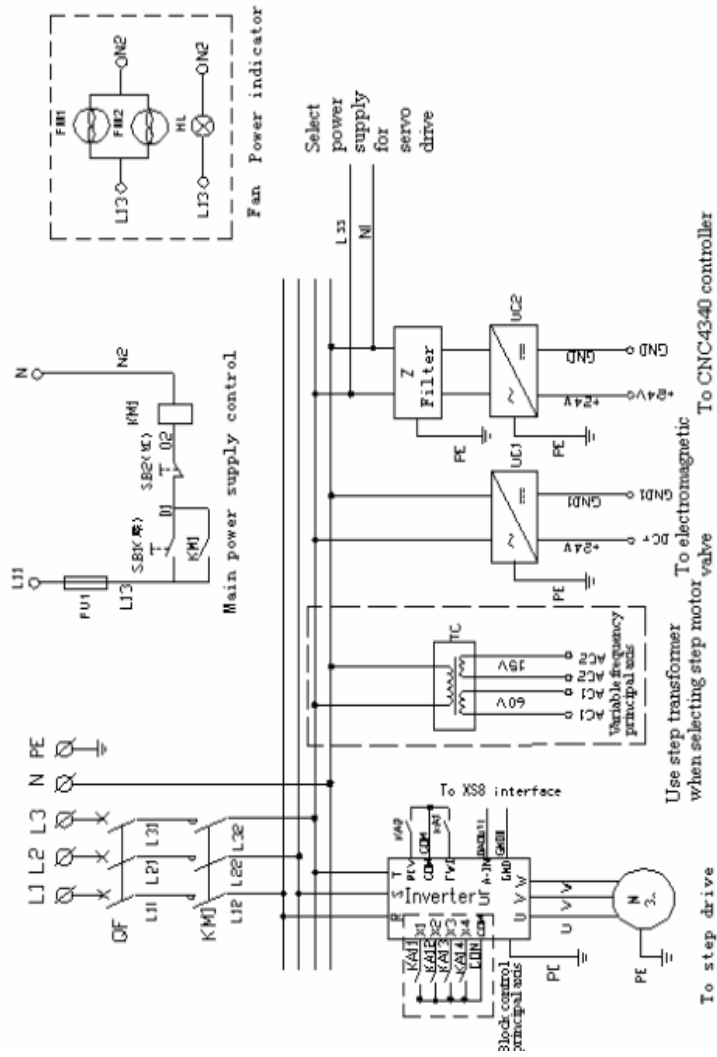

12.3.3 Servo drive connection diagram

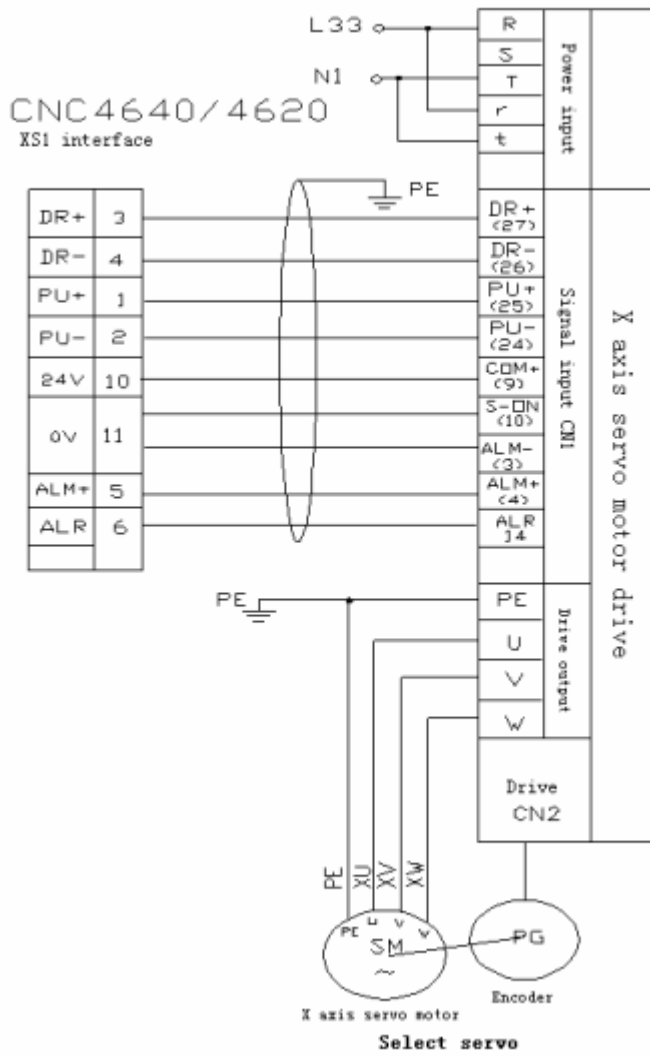

12.3.4 Step connection diagram

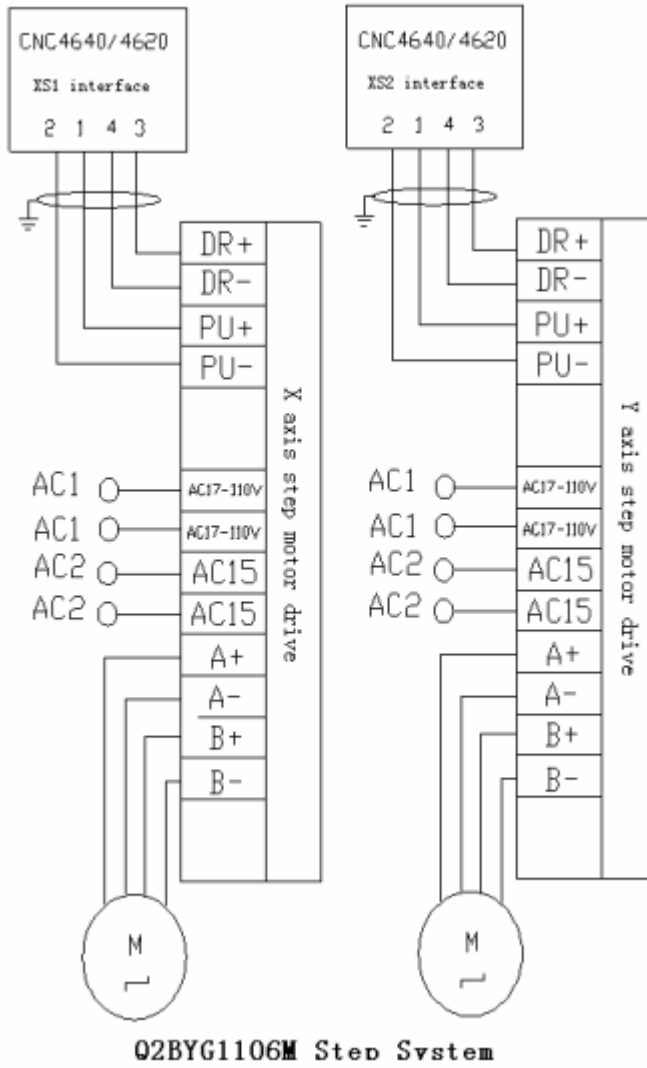

12.3.5 IO electrical connection diagram

